



www.regulus.eu



DBV2

Owners Manual
DBV2

EN

Thermal Safety Relief Valve Two-way Model

DBV2

Use

This thermal safety relief valve is designed to protect central-heating heat sources against overheating. The fill and drain valves in its brass body are controlled by 2 thermostatic elements. When the limit temperature is reached, the drain valve opens, enabling the overheated water escape from the heat source into the sewer system. At the same time, the filling valve opens to let cold water in from the mains. As soon as the water temperature drops below the limit, both the valves close.

If the pressure in the mains could be above 6 bar, it is necessary to install a pressure reducer at the inlet of cooling water. It should be installed as well if the pressure in the heating system is too high after cooling. In such cases the pressure of the reducing valve should be set approximately to a double value of the pressure required in the heating system, not less than 2 bar.

Warning: This valve is NO substitution for a safety valve!

Technical Data

Opening temperature (limit):	97 °C ±2 °C
Max. temperature:	110 °C
Max. pressure on the boiler side:	4 bar
Max. pressure on the water side:	6 bar
K _{vs} at 110 °C - stroke of two elements:	2.0 m ³ /hour
K _{vs} at 110 °C - stroke of one element:	1,3 m ³ /hour
Max. boiler output - stroke of two elements:	220 kW
Max. boiler output - stroke of one element:	140 kW

Installation

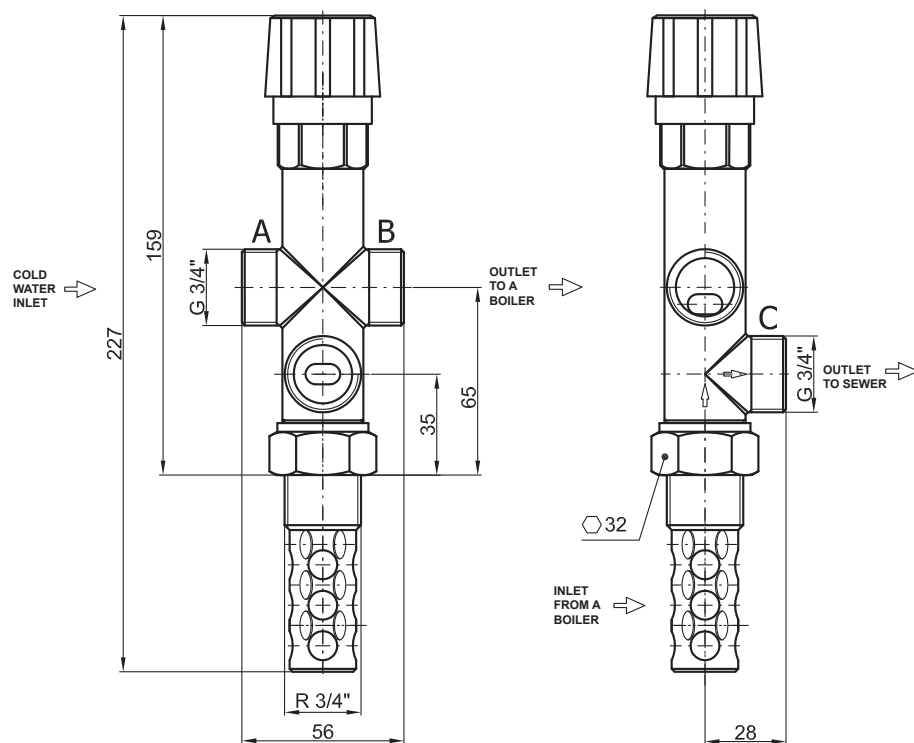
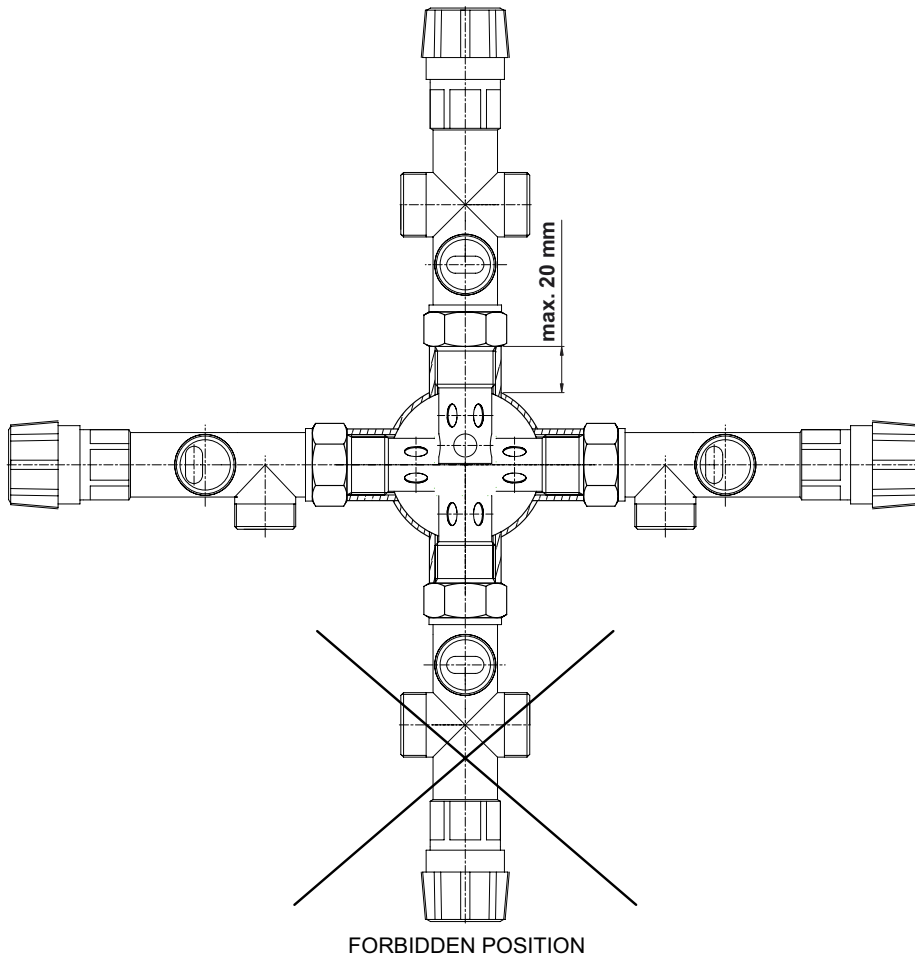

Fig. 1: Dimensional drawing

Installation may be done by qualified personnel only. On order to ensure flawless operation of this thermal safety relief valve (DBV2), it is necessary to respect the described installation conditions set by the manufacturer of your heating source and the flow directions marked on its body. DBV2 shall be always mounted to a position of the highest temperature in case of overheating (usually directly in the upper part of the source or in the feed pipe close to the heat source). When installing DBV2, it is important to check whether the 3/4" sleeve will ensure total immersion of the valve's thermostatic elements when mounted (see Fig. 2). After the valve is mounted into its sleeve, a sewer pipe shall be joined to point C (Fig. 1); hot water from the boiler will run this way to sewer. Cold water inlet shall be joined (as in Fig. 3) with pos. „A“ (Fig. 1) which will ensure cooling down the boiler when needed. A strainer shall be mounted into the cold water pipe to remove mechanical impurities. A pipe connecting the valve with the return line close to the boiler (as in Fig. 3) shall be joined with pos. „B“ (Fig. 1). Min. diameter of the connecting pipes is DN 16.

Always respect installation instructions from the manufacturer of your heat source. A precise position of the valve and a max. output and type of your heat source are also specified there.

DBV2 WORKING POSITIONS



The thermal safety relief valve can be mounted vertically as well as horizontally. In a horizontal position the hot water outlet marked „C“ (Fig. 1 and 2) must be facing downwards. The valve must not be installed with its head down!

Fig. 2: Working positions

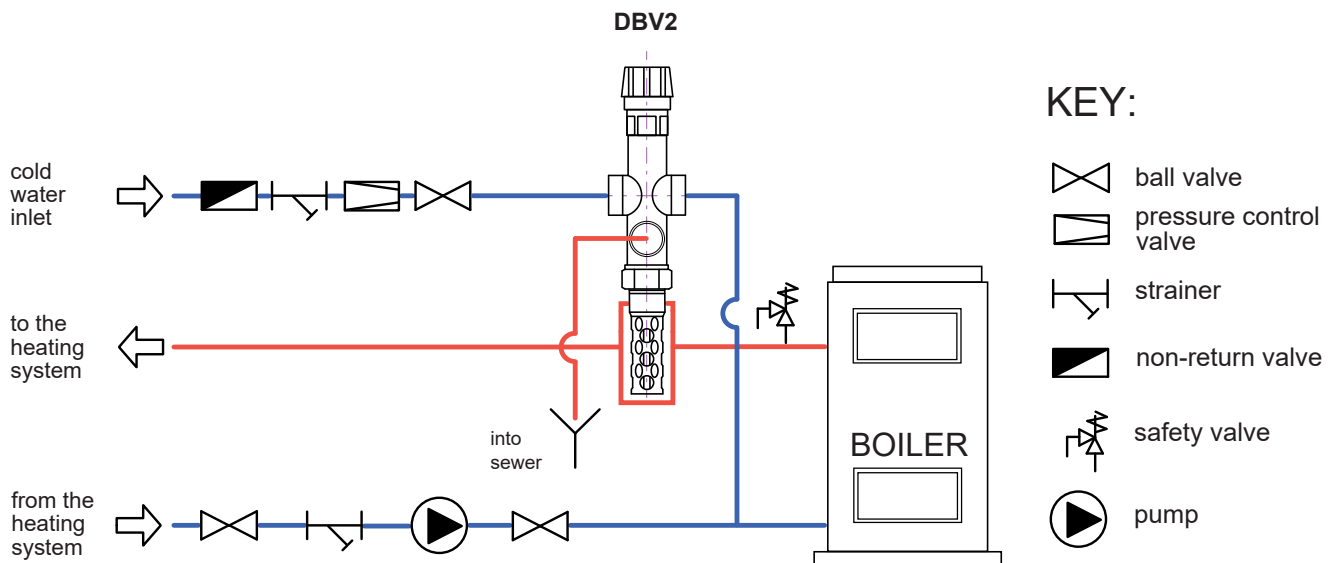

Fig. 3: Piping diagram for DBV2

Regular maintenance

Once a year: turn the head of the thermal safety relief valve in order to remove possible impurities. Clean the strainer at the cold water inlet.

WARRANTY CERTIFICATE

DBV2 Thermal Safety Relief Valve

WARRANTY CONDITIONS

1. The warranty period is 24 months from the date of purchase of the thermal safety relief valve or of a boiler, in case the valve is sold as a part of a boiler.
2. When claiming warranty, this Warranty Certificate must be submitted together with the purchase receipt.
3. The warranty is valid only if the technical conditions set by the Manufacturer are adhered to.
4. The warranty does not cover mechanical damage. The claimed defect must not be caused by tampering, improper installation or mounting position and improper handling, by using the product for other purposes than intended, by installation in improper conditions, and by a natural disaster.
5. Claims shall be settled by your dealer at the address shown below.

Purchase date:.....

Stamp print, signature of the salesman and address of the shop: