

Regulus

www.regulus.eu



CSE MIX-FIX W 5/4F

Installation and Operation Manual **EN**
CSE MIX-FIX W 5/4F PUMP STATION
with mixing valve and actuator, constant temperature

CSE MIX-FIX W 5/4F

1. Introduction

CSE MIX-FIX W 5/4F pump station is designed to be installed to a solid fuel boiler return line as a protection against low-temperature corrosion, flue gas condensation and boiler tarring. Further it can be installed to heating circuits, providing circulation of heating water through the circuit and mixing it to a preset constant temperature. A controller with a display ensuring actuator movement and circulation pump switching is integrated in the actuator.

This pump station is designed to be installed directly on the pipe, with 100 mm min. distance of the pipe axis from a wall.

2. Description of the pump station

The pump station consists of a YONOS PARA pump including a power cable, a 3-way mixing valve with a constant temperature actuator, incl. a power cable, two temperature sensors, a ball valve and insulation.

Main features	
Application	control of a solid fuel boiler return line temperature or control of flow temperature into a mixed circuit to a constant temperature level
Description	The pump station consists of a WILO Yonos Para RS 25/7,5 pump, a 3-way mixing valve LK 840 with ACC40 actuator and insulation.
Function	the pump station keeps a constant temperature at a boiler return line or at a mixed heating circuit flow and turns on/off circulation pump depending on mode and temperature settings
Working fluid	water, water-glycol mixture (max. 1:1) or water-glycerine mixture (max. 2:1)
Installation	return pipe of a solid fuel boiler / flow pipe into a heating circuit, the min. distance of the pipe axis from a wall is 100 mm
Code	16 216

Technical data of CSE MIX-FIX W 5/4F pump station	
Fluid working temperature	5 - 110 °C
Max. working pressure	6 bar
Ambient temperature	5 - 40 °C
Max. rel. humidity	95 % non condensing
Power supply	230 V, 50 Hz
Insulation material	EPP RG 60 g/l
Overall dimensions	325 x 140 x 220 mm
Total weight	4.2 kg
Connections	3 x G5/4" F

3. Installation options

The pump station comes with a mixing valve in the right-hand position (see Fig. 1). If this installation position is convenient, there is no need to make any adjustments. When needed, the mixing valve can be rotated to the left of the boiler (see Fig. 2). After the valve is turned by 180° and the fittings are tightened, the actuator lock shall be unscrewed and screwed into the opening at the other valve side (see Fig. 3) the position of the valve member and actuator changed (see the paragraph and figures below).

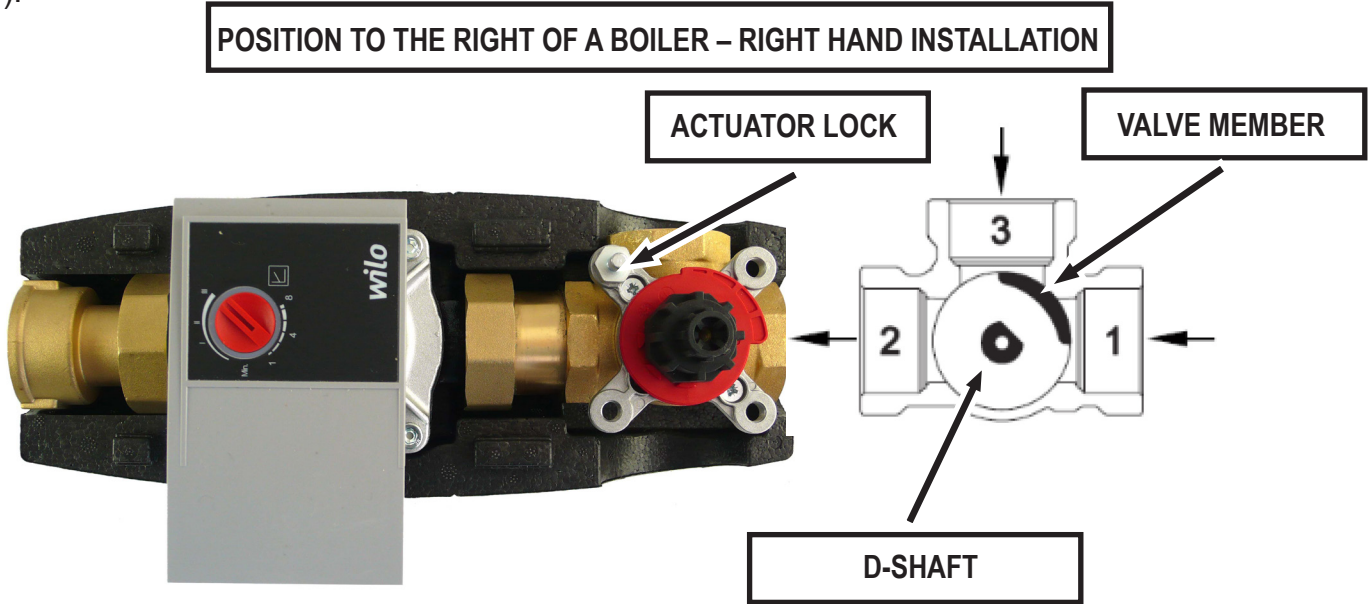

Fig. 1

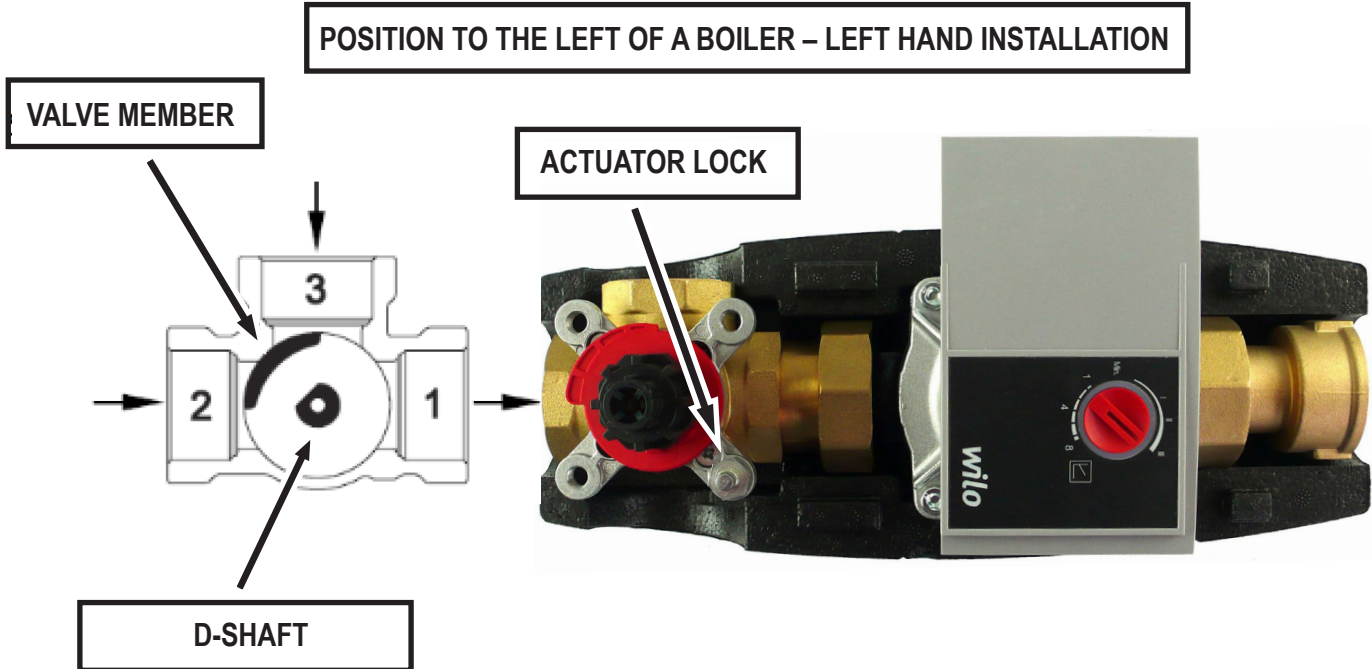

Fig. 2

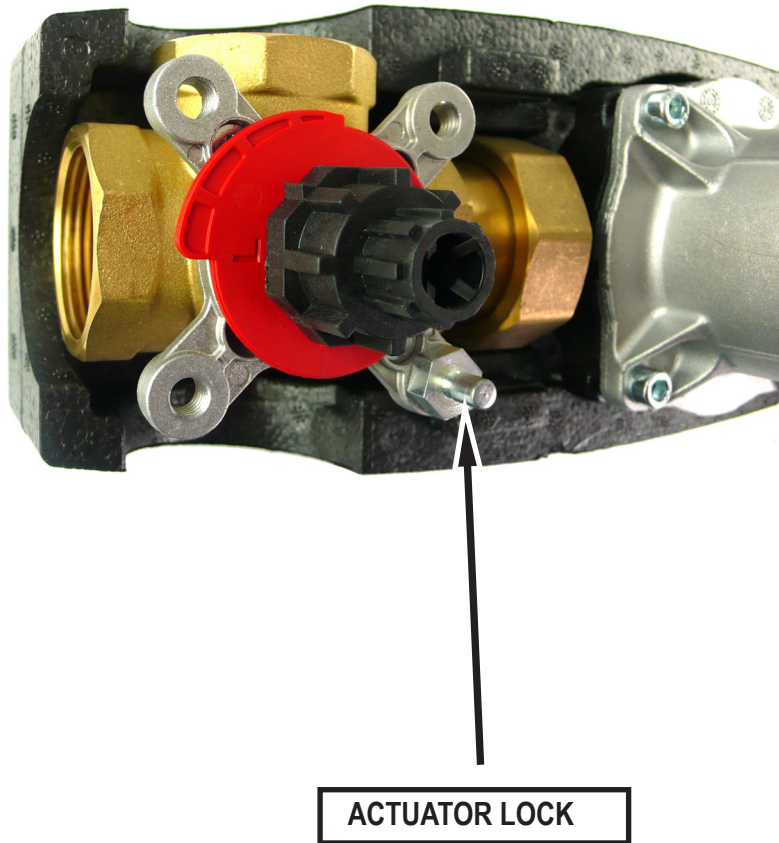

Fig. 3

Actuator adjustment

Having turned the valve to the left hand position, turn the D-shaft in such a manner that the valve member is between inlets 2 and 3, turn the plastic red wheel into its proper position (see Fig. 4), and finally fit the plastic adapter (see Fig. 5).

The flat edge of the shaft and the arrow on the plastic adapter are located on the same side as the valve member!

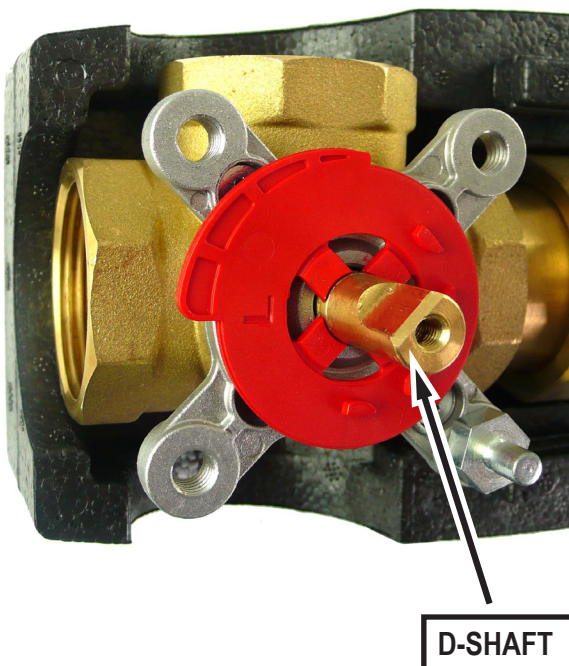

Fig. 4

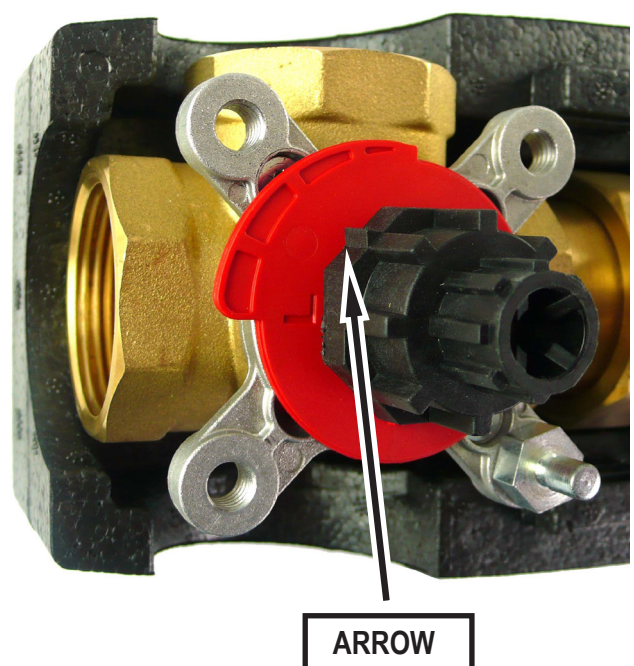
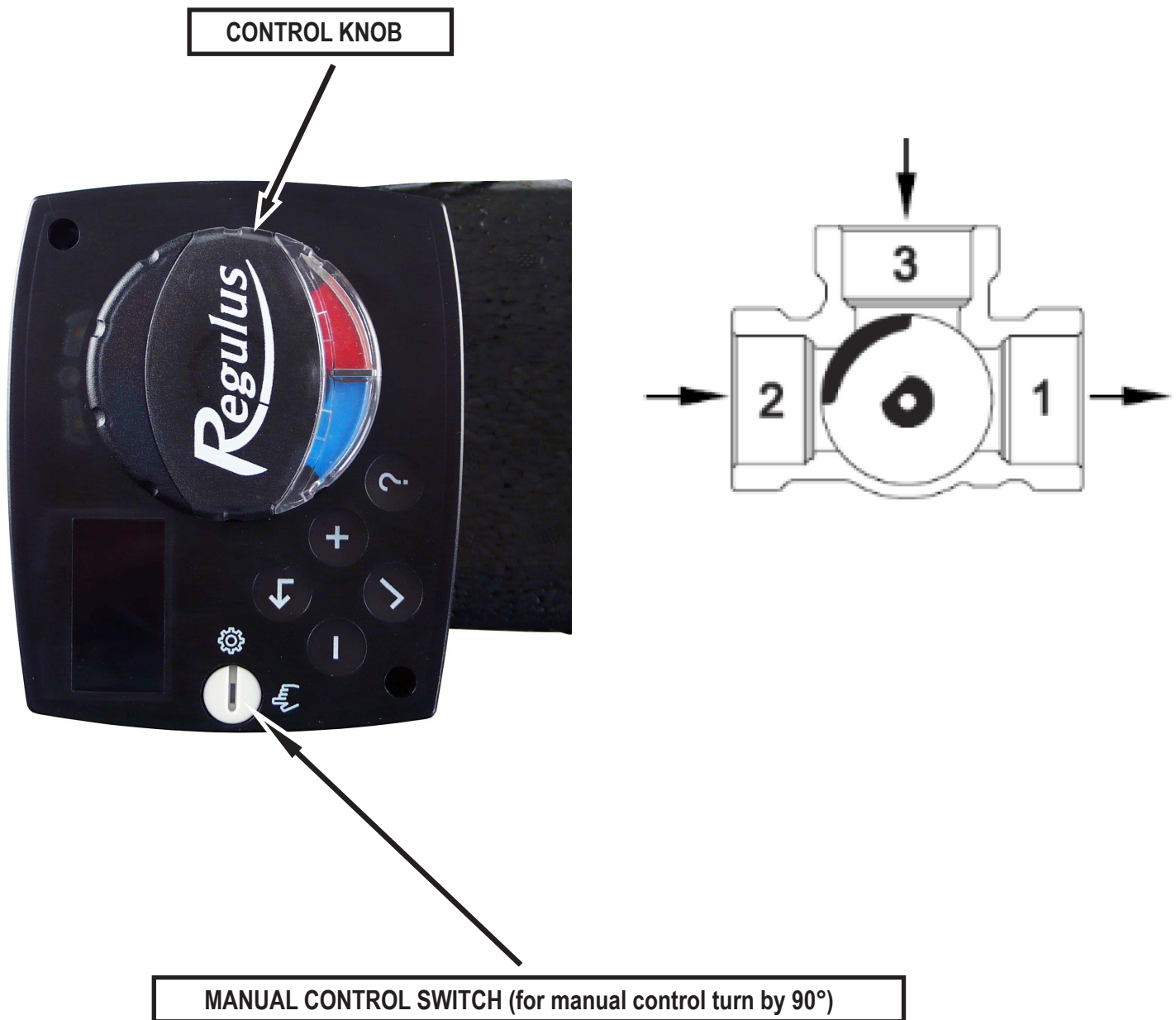

Fig. 5

Prior to fitting the actuator on the plastic adapter, switch it to manual control, set the control knob to the middle of its control range and then fit the actuator onto the adapter already on the valve. The control knob shall be able to turn freely both to left and right by 45°. When turned to the right by 45°, the path 3 is closed, and when turned to the left by 45° the path 2 is closed. Having performed the check, turn the knob back to automatic control.



After the actuator is fitted, the correct position of the round indication label (hot/cold, red/blue) shall be checked as to the right function and position of the valve.

In case of a horizontal installation on a solid fuel boiler return line, the red mark on the label shall be on the right-hand side for right-hand installations (the pump station to the right of the boiler, see Fig. 6) and on the upper side for left-hand installations (the pump station to the left of the boiler, see Fig. 7).



Fig. 6



Fig. 7

In case of a vertical installation in a heating system, the red mark on the label shall be on the right-hand side for left-hand installations (the bypass pipe of the mixing valve to the left, see Fig. 8) and on the left-hand side for right-hand installations (the bypass pipe of the mixing valve to the right, see Fig. 9).



Fig. 8

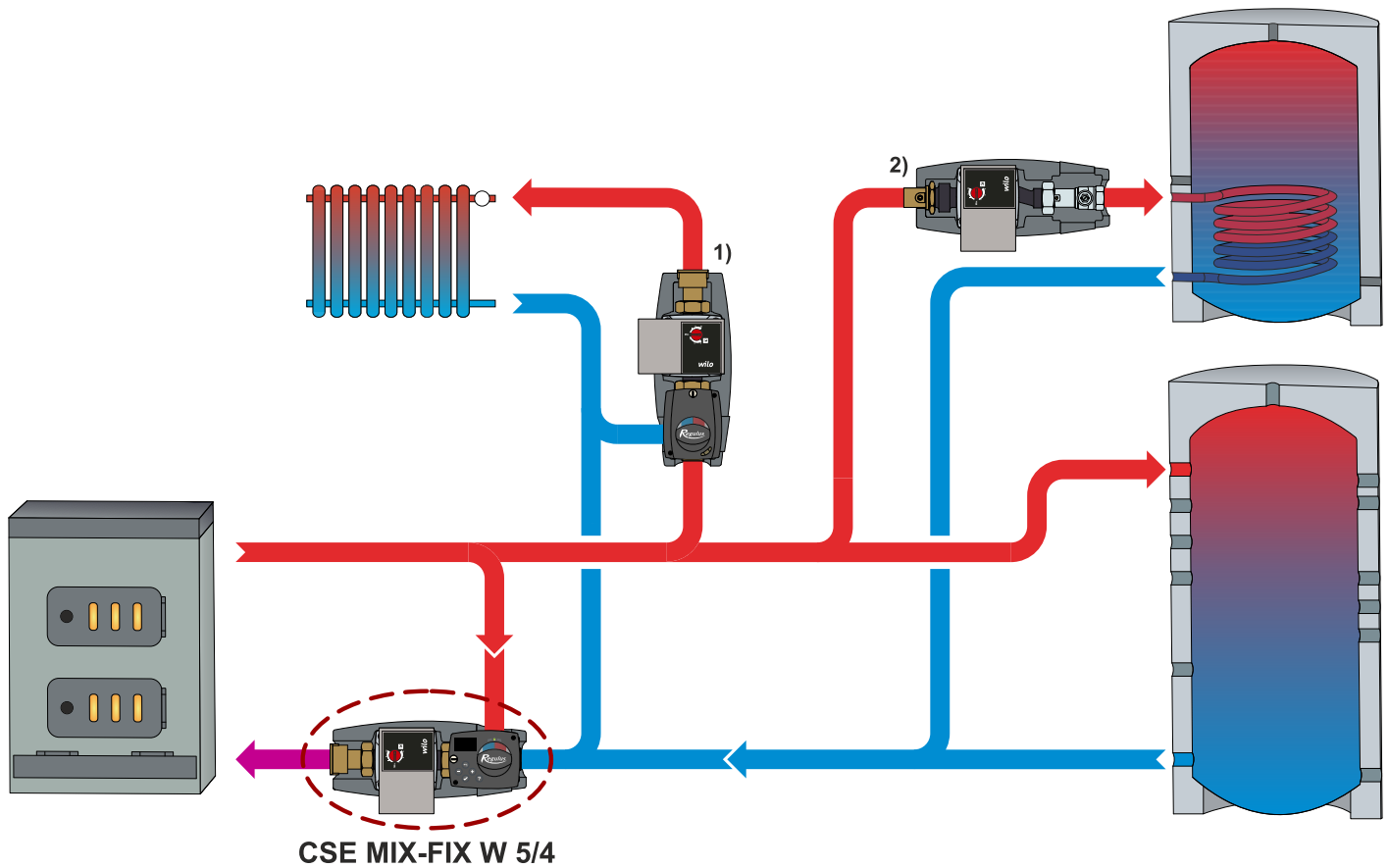

Fig. 9

4. Pump Station Connection Diagram

The pump station may be installed in either horizontal or vertical position.

CSE MIX-FIX W 5/4



- 1) CSE MIX W1F - Code 16219
CSE MIX W1M - Code 16082
CSE MIX W5/4F - Code 16215
CSE MIX W5/4M - Code 16848
- 2) CSE OTS ZV W - Code 15892

5. LK Mixing Valve



Technical data	
Working temperature	5 - 110 °C (120°C in short term)
Max. working pressure	10 bar
Ambient working temperature	5 - 60 °C
Valve K_{vs}	16.0 m ³ /h
Max. pressure difference	5 m H ₂ O
Leakage rate	< 1% K_{vs} at 5 m H ₂ O pressure difference
Connections	3 x G 5/4" F

Materials	
Valve housing, spindle, member	brass
Seal	EPDM

Valve pressure drop graph

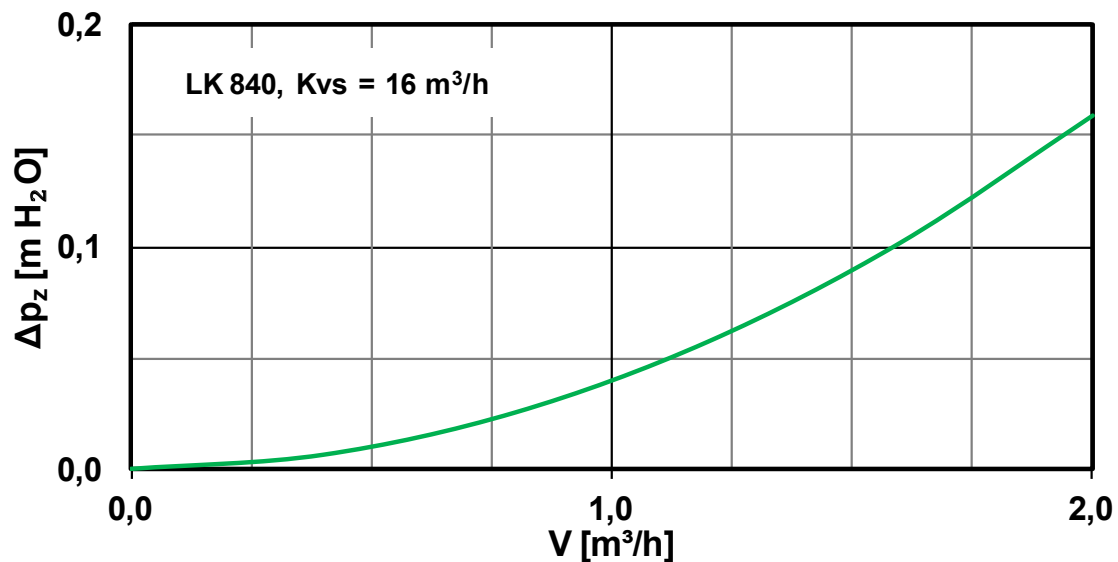

6. Mixing Valve Actuator

For adjustments to the actuator, see its Instruction Manual (included in the supply).



Technical data	
Torque	6 Nm
Angle of rotation	90°
Shift time	120 s
Control	constant temperature
Auxiliary switch	none
Power supply	230 V AC
Max. power input	3.5 VA
IP rating	IP42
Protection class	I by EN 60730-1
Ambient temperature	5 - 40 °C
Cable (cross section area - length)	3 x 0.5 mm ² - 2 m, type E
Temperature sensors	2 x Pt1000

Actuator installation and sensors connection

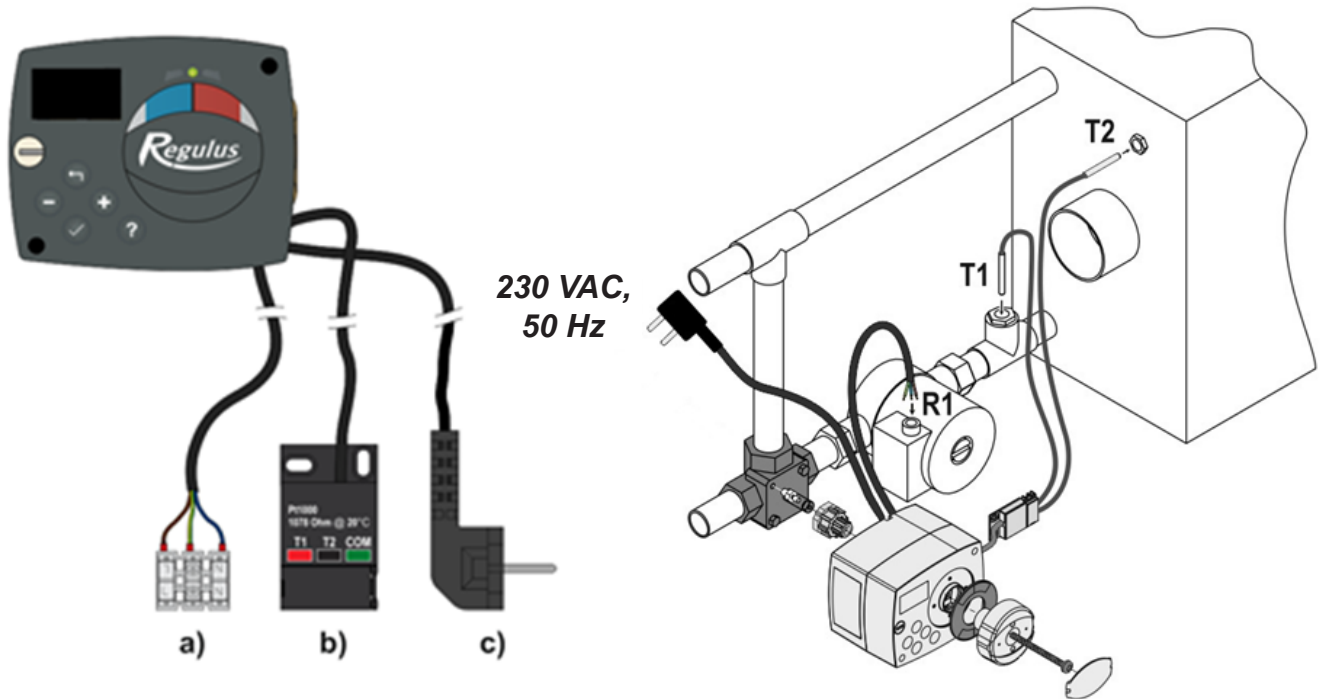

- a) connection for circulation pump switching on/off (R1)
- b) Pt1000 temperature sensors connection (T1, T2)
- c) 230 V AC, 50 Hz power supply

7. YONOS PARA RS 25/7.5 RKC 130 mm Pump

Design

Wet-running circulation pump with G 6/4" M connection.

Electrical data	
Power supply	230 V, 50 Hz
Power input (min./max.)	4/75 W
Current (min./max.)	0.04/0.66 A
IP rating	IPX4D
Max. speed	4770 rpm
Energy Efficiency Index	≤ 0.21 by EN 16 297/3
Motor protection	integrated

Minimum pressure at the suction port	
Min. pressure at the suction port to avoid cavitation	0.05 bar at 50 °C
	0.43 bar at 95 °C

Operation data	
Fluid working temp.	0 - 100 °C at 58 °C ambient temperature
Max. working pressure	6 bar
Max. head	7.6 m

Wilo Yonos Para pump wiring

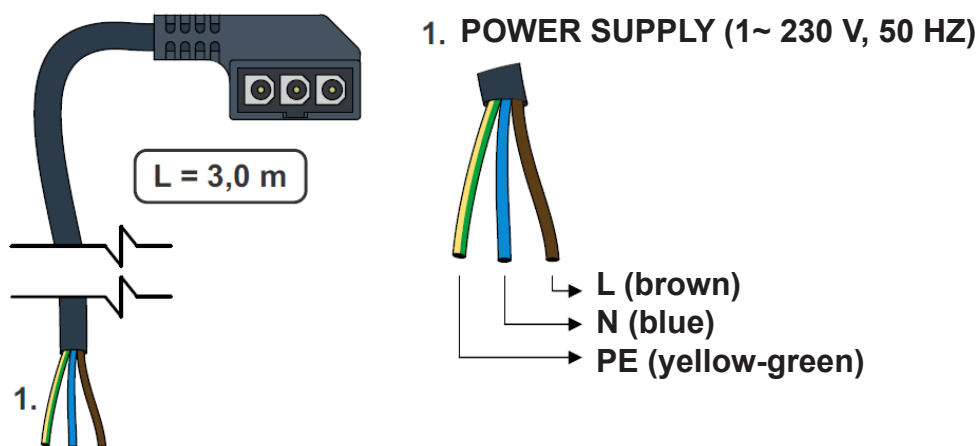

Performance curves

Characteristics of Δp -v (variable)

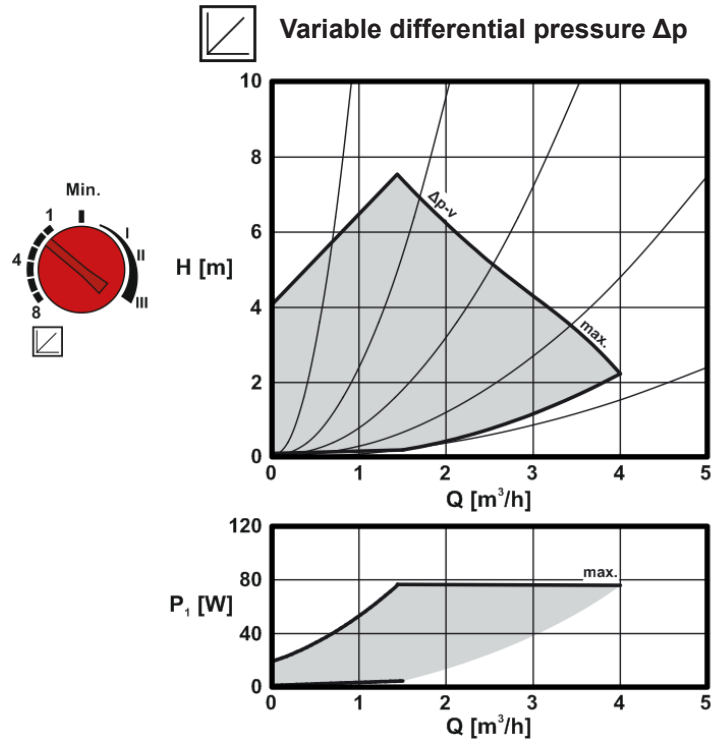

Characteristics of $n = \text{const.}$

