

Regulus

www.regulus.eu



PS 80 Z

Installation and Operation Manual
WALL-HUNG THERMAL STORE
PS 80 Z

EN

PS 80 Z

CONTENTS

1 Description	3
1.1 Tank protection	3
1.2 Connection points on the tank	3
1.3 Packaging	3
2 General Information	3
3 Technical Data and Dimensions of P 80 Z Tank	4
4 Operation	5
5 Examples of Assigning Connection Points	5
6 Installation and Commissioning	6
6.1 Connection to heat sources	6
6.2 El. heating element installation	6
6.3 Commissioning	6
7 Maintenance	7
8 Disposal	7
9 Warranty	7

1 - Description

The wall-hung thermal store PS 80 Z is intended for storing and subsequent distribution of thermal energy. It is suitable as a buffer tank for inverter heat pumps to ensure a sufficient volume of water for defrosting the evaporator. The tank has four G 1" M connections for connecting a heat source and a heating system. It comes with insulation and parts for hanging the thermal store on a wall.

If needed, an electric heating element without a thermostatic head can be installed in the tank, 7.5 kW max. output, for codes kindly consult the Catalogue.

1.1 - Tank protection

Its inner surface is without surface treatment and anti-corrosion protection. Its painted outer surface is fitted with insulation made of hard PU foam that is covered with lacquered sheet metal.

1.2 - Connection points on the tank

4x G 1" M connections for connecting a heat source and heating system

1x G 1/2" F connection for air vent valve

1x G 6/4" F connection for installing an electric heating element

2x sensor sheaths \varnothing 12.6 mm

1.3 - Packaging

Tanks are packed in foil and supplied in a box filled with polystyrene.

2 - General Information

This Operation Manual is an integral and important part of the product and must be handed over to the User. Read carefully the instructions in this Manual as they contain important information concerning safety, installation, operation and maintenance. Keep this Manual for later reference. The appliance shall be installed by a qualified person according to valid rules and Manufacturer's Instructions.

This device is designed to store heat in heating water and its subsequent distribution. It must be connected to a heating system and heat sources.

Using the thermal store for other purposes than above described (e.g. as a hot water storage tank) is forbidden and the manufacturer accepts no responsibility for damage caused by improper or wrong use.

3 - Technical Data and Dimensions of P 80 Z Tank

Technical Data	
Total tank volume	77 l
Max. temperature in tank	80 °C
Max. pressure in tank	3 bar
Tank diameter	400 mm
Tank diameter with insulation	450 mm
Tank overall height	865 mm
Tank perimeter insulation thickness	25 mm
Bottom insulation thickness	25 mm
Top insulation thickness	25 mm
Tipping height	980 mm
Empty weight with insulation	36 kg

Materials	
Tank material	steel
Tank insulation material	PUR foam
Outer surface of the insulation	sheet metal

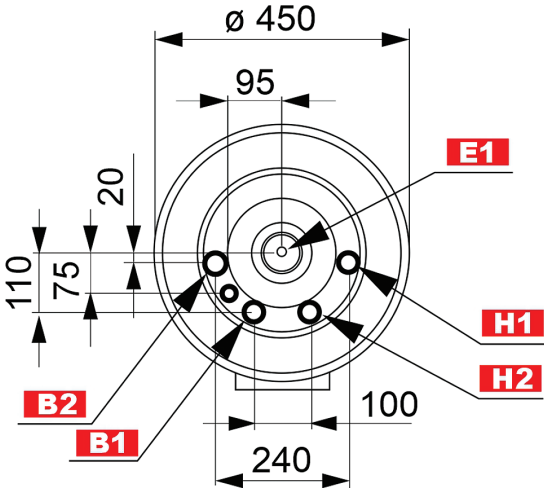
Dimensions		pos.	description	connections
Heat sources				
	B1	Inlet from heat source	G 1" M	
	B2	Return to heat source	G 1" M	
Heating system				
H1	Flow to heating system	G 1" M		
H2	Return from heating system	G 1" M		
Auxiliary heat source				
E1	Electric heating element	G 6/4" F		
Control and safety				
O	Air discharge	G 1/2" F		
C1	Sheath	ø 12,6 mm		
C2	Sheath	ø 12,6 mm		

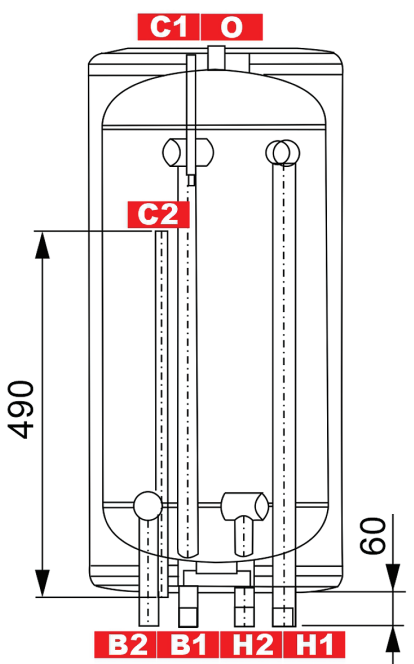
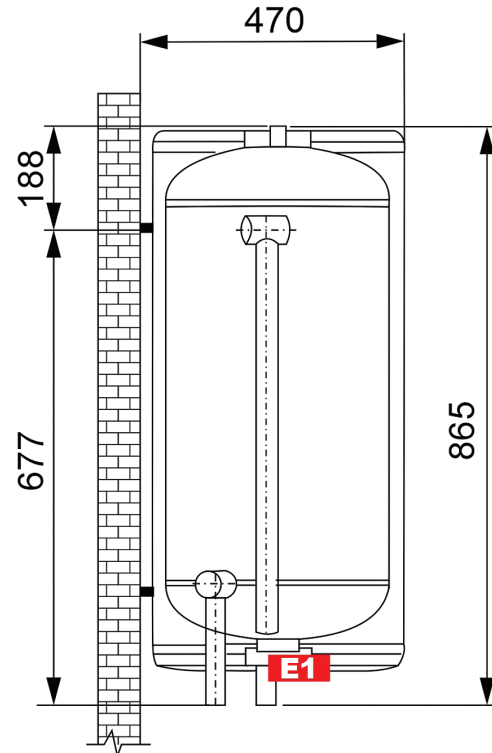
Minimum tank hanging height from the floor when installing a 7.5 kW heating element – 650 mm

4 - Operation

The thermal store is suitable as a buffer tank for inverter heat pumps to ensure a sufficient volume of water for defrosting the evaporator, but it can also be used to store thermal energy also with other heat sources, such as various types of hot water boilers or electric heating elements.

5 - Examples of Assigning Connection Points

Example I.

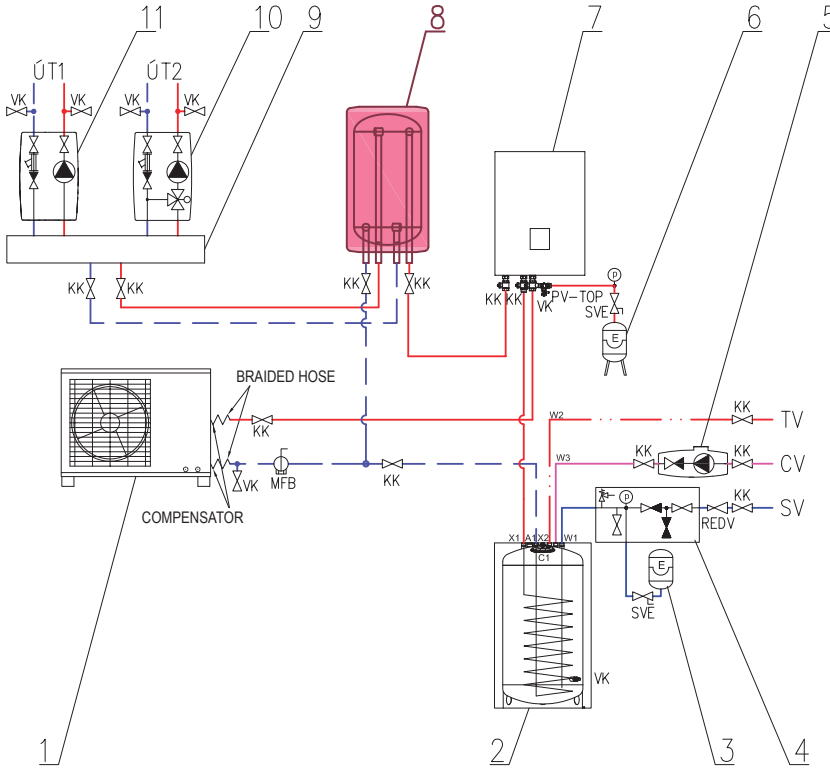

KEY

- 1 - Regulus heat pump (RTC, CTC)
- 2 - hot water storage tank (e.g. NBC 170 HP)
- 3 - DHW expansion vessel
- 4 - safety kit for HW storage tank
- 5 - pump station for DHW recirculation – CSE TV ZV
- 6 - heating system expansion vessel
- 7 - RegulusBOX indoor unit
- 8 - **PS 80 Z thermal store**
- 9 - HV 60/125-2 manifold/collector
- 10 - pump station for heating circuit 2 – CSE2 MIX
- 11 - pump station for heating circuit 1 – CSE2
- SV - cold water
- TV - hot water
- CV - hot water recirculation
- ÚT - central heating (heating system)
- KK - ball valve
- ZV - check valve
- AOV - automatic air vent valve
- PTR - pressure temperature relief valve
- REDV - pressure reducing valve (optional)
- VK - drain valve
- SVE - expansion vessel service valve
- PV-ÚT - safety valve for heating system
- MFB - Magnet Filterball

Example II.

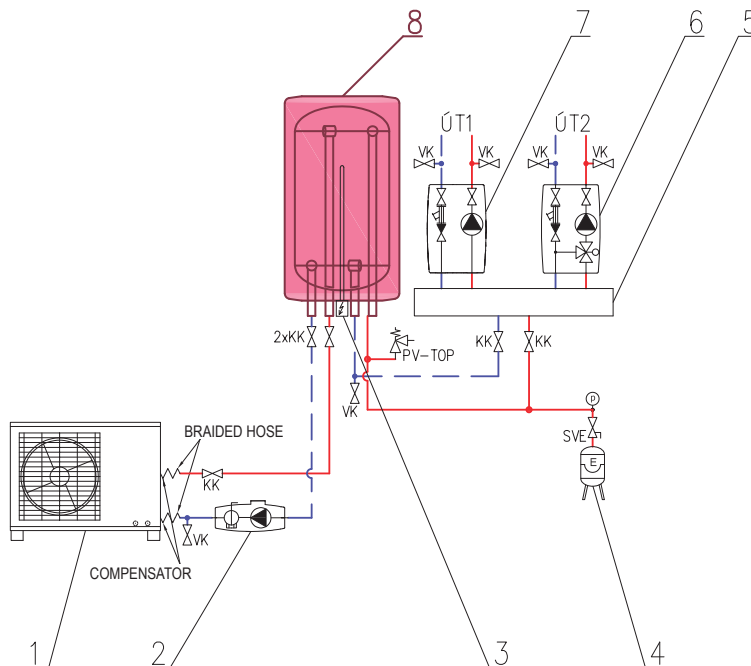

KEY

- 1 - Regulus heat pump (RTC, CTC)
- 2 - CSE TC W PWM MFB pump station
- 3 - electric heating element, 7.5 kW max.
- 4 - heating system expansion vessel
- 5 - HV 60/125-2 manifold/collector
- 6 - pump station for heating circuit 2 – CSE2 MIX
- 7 - pump station for heating circuit 1 – CSE2
- 8 - **PS 80 Z thermal store**
- ÚT - central heating (heating system)
- KK - ball valve
- ZV - check valve
- AOV - automatic air vent valve
- VK - drain valve
- SVE - expansion vessel service valve
- PV-ÚT - safety valve for heating system
- MFB - Magnet Filterball

6 - Installation and Commissioning

Installation must meet valid rules and may be done only by qualified staff.

Defects caused by improper installation, use or handling are not covered by warranty.

Prior to the tank installation, check the load-bearing capacity and material of the supporting structure with regard to the weight of the tank full of water, i.e. 113 kg. Fasten the installation plate to the supporting structure with two 8x80mm hex-head screws into 12mm dowels. All these parts are included in supply - see pic. Then hang the tank on the installation plate.



Should the tank be equipped with an electric heating element, it should be installed prior to connecting heating system pipes.

After the tank is installed and connected to an existing heating system, it is recommended to clean the entire heating system using a suitable cleaning agent, e.g. MR-501/R.

Anti-corrosion protective liquid should be also used, e.g. MR-501/F.

6.1 - Connection to heat sources

Hang the tank on the wall as close as possible to the heat source (minimum height of the tank from the floor must be at least 650 mm when a 7.5 kW heating element is installed). Connect the heat source and heating system to the inlets and outlets. Install an air vent valve at the highest point of the system. Insulate all the connecting piping.

6.2 - El. heating element installation

The thermal store can be equipped with an electric heating element without a thermostatic head (e.g. ETT-A), up to 7.5 kW output with a maximum length of 635 mm.

It is recommended to use an encased adjustable thermostat with 1.5m capillary, code 10772. Place the thermostat sensor into the C2 lower sheath.

An electric heating elements without thermostatic head shall be protected by a safety thermostat.

It is recommended to use an encased safety thermostat with 1.3m capillary, code 19548. Place the thermostat sensor into the C1 upper sheath.

The installation may be done by qualified staff only.

6.3 - Commissioning

Ground the tank before commissioning.

The tank shall be filled up together with the heating system, respecting valid standards and rules. In order to minimize corrosion, special additives for heating systems should be used, e.g. MR-501/F. The quality of heating water, top-up water and the frequency of topping up has a strong influence on the lifetime of the heating system. Poor quality of heating water may cause problems like corrosion or incrustation.

Fill the entire system with the heating fluid and air-bleed it. Check all connections for leaks and verify the system pressure. Set the parameters of the used controller in compliance with the documentation and manufacturer's recommendations. Check regularly the proper function of all control and adjustment elements.

7 - Maintenance

If the tank is fitted with a heating element, disconnect it from the mains first. Clean the exterior of the tank with a soft cloth and a mild detergent. Never use abrasive cleaners or solvents. Check all tank connections for leaks.

8 - Disposal

Packaging shall be disposed of in compliance with the valid rules. When the product reaches the end of its life, it shall not be disposed of as household waste. It shall be dropped off at a Local Waste Recycling Centre. Insulation shall be recycled as plastic and the steel vessel as scrap iron.

9 - Warranty

This product is covered by warranty according to the conditions described in this Manual and according to the Warranty Certificate. A Warranty Certificate is an integral part of the supply.

