

Installation guide

Recooling Thermostatic Valve, BVTS Model



CE

EN
v. 1.0

Regulus

Application

BVTS Recooling Thermostatic Valve is designed to protect solid fuel boilers from overheating. It dissipates heat from a boiler recooling heat exchanger by opening its cold water inlet which protects boiler from overheating.

Other application of BVTS is for flooding a pellet feeder with water before pellets ignite in the storage bin.

The valve is fitted with 2 temperature sensors. Should one fail, the other shall ensure proper operation of the valve.

The valve meets the requirements set by the Pressure Equipment Directive (PED) 97/23/ EC and EN 14597. It is a STW device of Th type as defined by EN 14597, so it fulfils the requirements for a device to dissipate excess heat, as of Art. 4.3.8.4, EN 303-5.

This thermostatic valve does not replace a safety valve for a heat source.

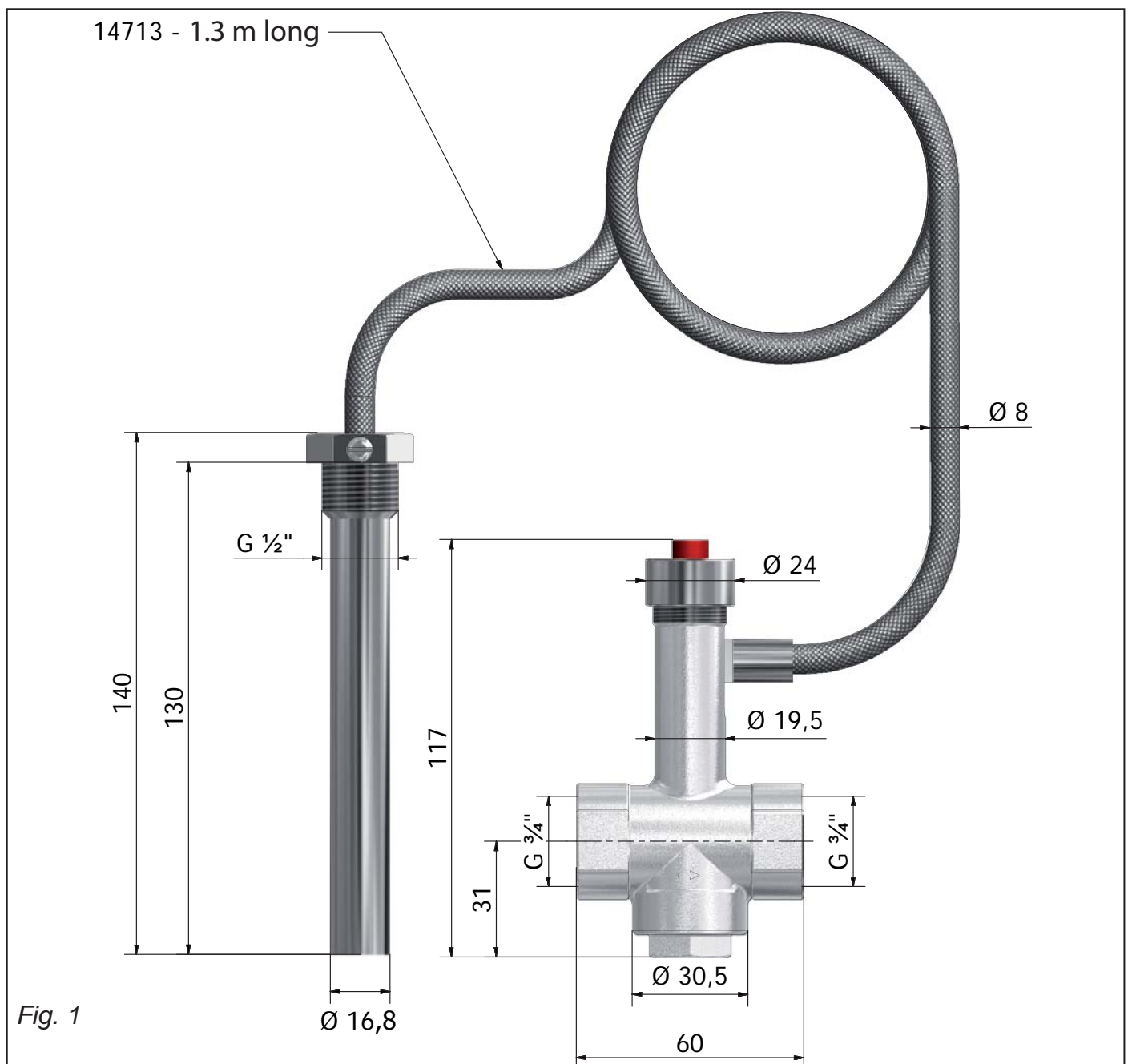

Technical Data:	
Nominal diameter:	DN 20
Pipe connection	G 3/4" F
Heat source connection	G 1/2" M
Nominal pressure	PN 10
Max. working pressure - heating fluid	6 bar
Max. working pressure - cooling water	10 bar
Ambient temperature	0 to 80 °C
Hysteresis	6 °C
Kvs at the opening temp. + 13 °C	2.6 m ³ /h

Materials:	
Valve body	forged brass, nickel-plated
Metal parts	forged brass, nickel-plated
Spring	stainless steel
Sensor	copper
Capillary tube	copper
Sheath	brass, nickel-plated brass
Activation push button	ABS
O-rings and sealing inserts	EPDM, NBR

Installation

The valve shall be installed as close to a boiler as possible, and its sensor shall be placed at the hottest spot, see Fig. 2 BTVS - (A).

The valve shall be installed at a fuel feeder, and the sensor shall be placed inside the fuel feeder, see Fig. 2 BTVS - (B).

The valve may be installed in any position.

Prior to installation, the system shall be free of dirt that could jam the valve seat and cause a failure. The flow direction is indicated by the arrow on the valve body.

The inlet water pressure to valve shall follow the recommendation of the boiler manufacturer.

A strainer shall be installed upstream of the valve, see Fig. 2.

Max. tightening torque for the sheath is 30 Nm.

After installation, proper functioning of the valve shall be checked.

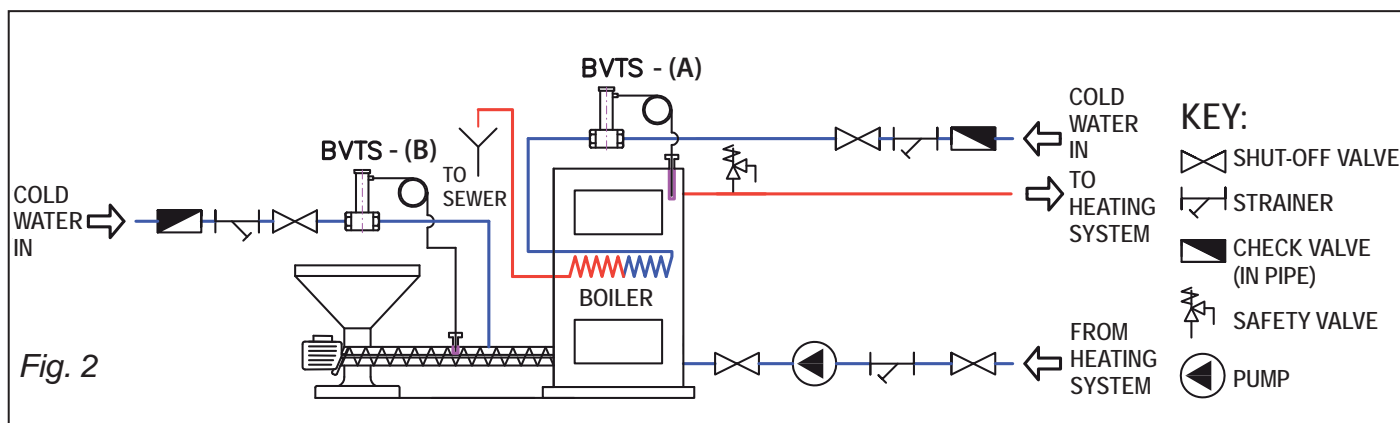

Maintenance

Check once a year that the valve works properly. This function check is performed manually, namely by pressing the red push button that opens flow through the valve. **The nut holding the red push button shall be neither tightened nor loosened!**

Check and clean the strainer at the cooling water inlet at least once a year.

BVTS Recooling Thermostatic Valves with non-standard opening temperatures:

English	Code	Opening temperature:	Max. sensor temperature:
	14713	97 ± 2 °C	125 °C