

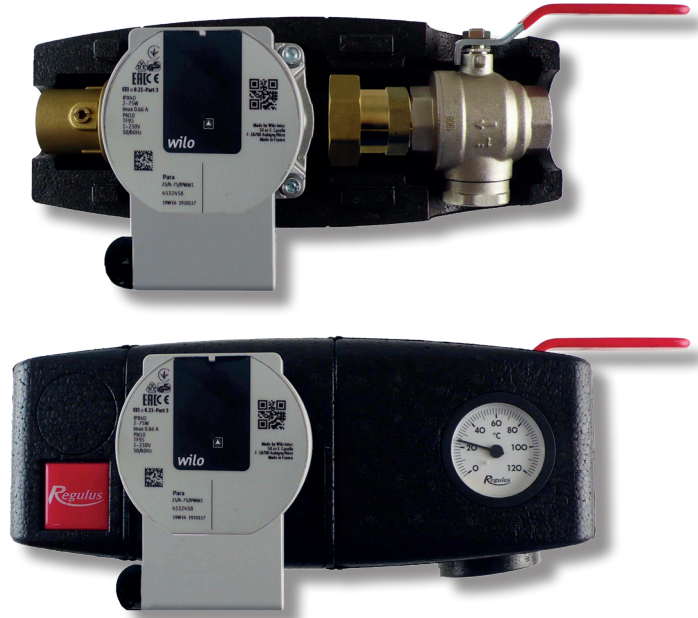

[www.regulus.eu](http://www.regulus.eu)



CSE TC W iPWM MFB

Installation and Operation Manual  
**CSE TC W iPWM MFB PUMP STATION**

**EN**

**CSE TC W iPWM MFB**

# 1. Introduction

CSE TC W iPWM MFB pump station is designed to be installed on the return pipe to the heat pump, where it ensures circulation through the heat pump circuit. The circulation pump is switched by an external controller, the pump speed controlled by PWM signal. With no PWM signal the pump runs at max. speed. The pump station includes 2 ball valves, one of them with integrated strainer and magnet. The strainer can be easily removed and cleaned without any tools. The pump station is designed for installation directly on a pipe with a min. pipe centre distance from a wall of 100 mm.

# 2. Description of the pump station

The pump station consists of a Wilo PARA 25/8 iPWM1 130 mm, ball valve w. filter and magnet, thermometer, insulation.

Main features	
Application	heat pump circuit
Description	consists of PARA 25/8 iPWM1 130 mm pump, 2 ball valves (one with strainer and magnet), thermometer, insulation
Working fluid	water, water-glycol mixture (max. 1:1) or water-glycerine mixture (max. 2:1)
Installation	return pipe of a heat pump, 100 mm min. pipe centre distance from wall
<b>Code</b>	<b>17868</b>

Technical data of CSE TC W iPWM MFB pump station	
Fluid working temperature	5 - 95 °C
Max. working pressure	10 bar
Max. ambient temperature	40 °C
Power supply	1 ~ 230 V, 50 - 60 Hz
Insulation material	EPP RG 60 g/l
Overall dimensions	380 x 170 x 180 mm
Total weight	3.4 kg
Connections	2 x G 1" F

Technical Data of Ball Valve w. Filter and Magnet	
Max. fluid temperature	100 °C
Max. working pressure	16 bar
Magnetic induction	1.2 T (12000 Gs)
Filter mesh size:	0.6 mm
Connections	G 1" F

### 3. Flow direction

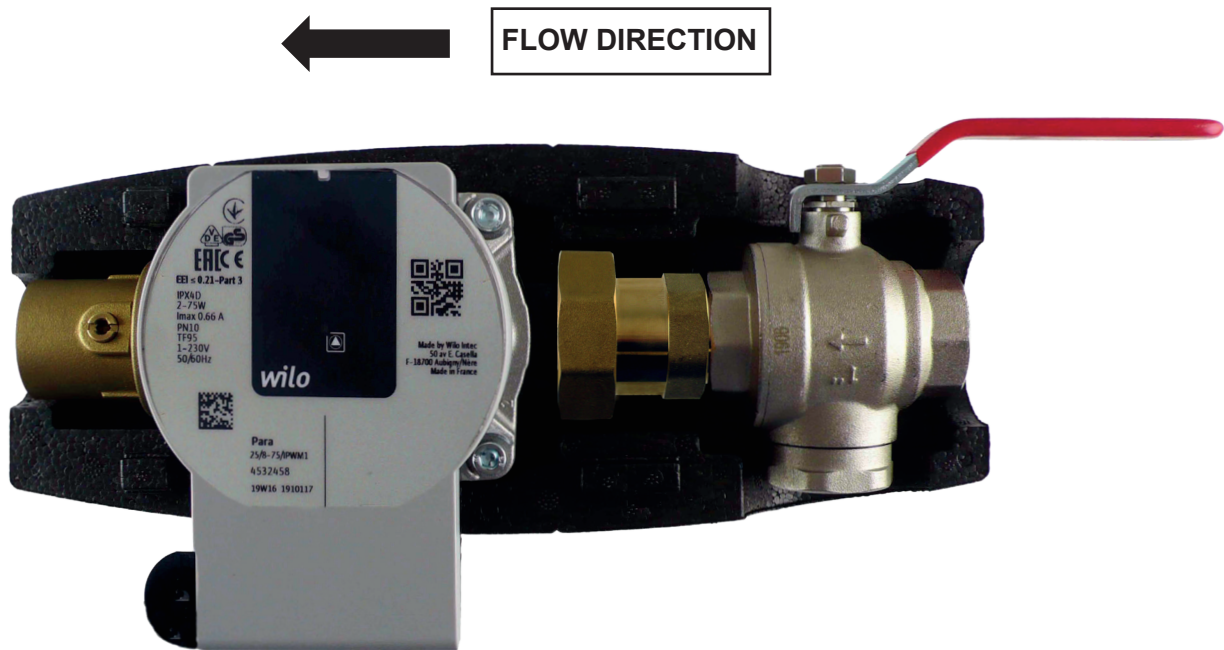

### 4. Wilo-Para iPWM1 Pump

#### 4.1. General Information



The Wilo Para 25/8 iPWM1 is a wet running circulation pump. The pump speed is controlled by the PWM signal. When the PWM signal is disconnected, the pump runs at its maximum speed. The operating status and possible faults of the pump are indicated by LEDs directly on the pump. The pump can send the current flow rate electronically to an external controller. The controller needs to be equipped with an iPWM read input and a flow rate calculation function.

The high efficiency circulation pumps of the PARA iPWM1 series are used exclusively for the circulation of liquids in hot water heating systems. Operating the pump in other systems or in systems containing too little water, air bubbles or not pressurized can lead to its rapid destruction.

## 4.2. Permitted and Prohibited Pump Positions

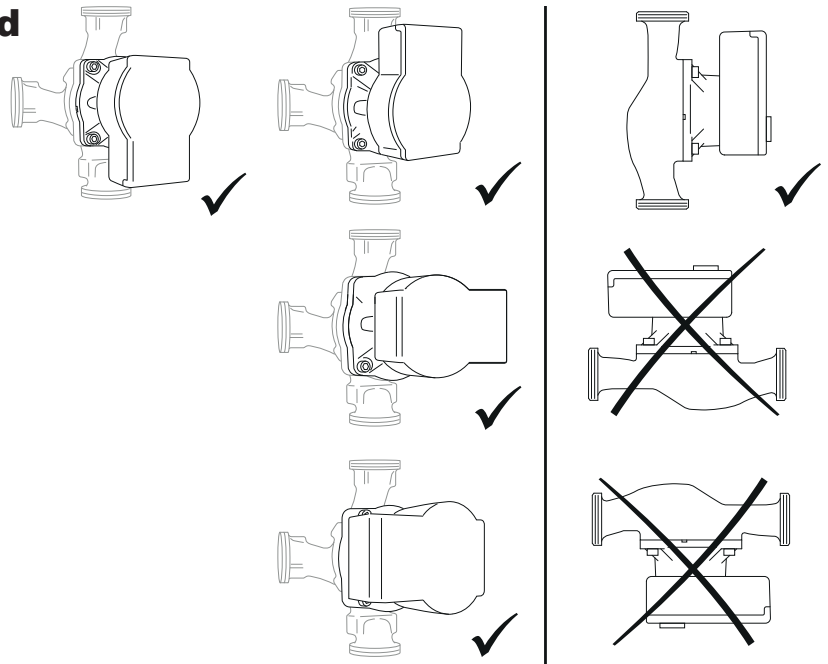

## 4.3. Pump Wiring

The pump must be wired / disconnected by a qualified person in compliance with EN 50110-1!

### Wilo PARA 25/8 iPWM1 pump wiring

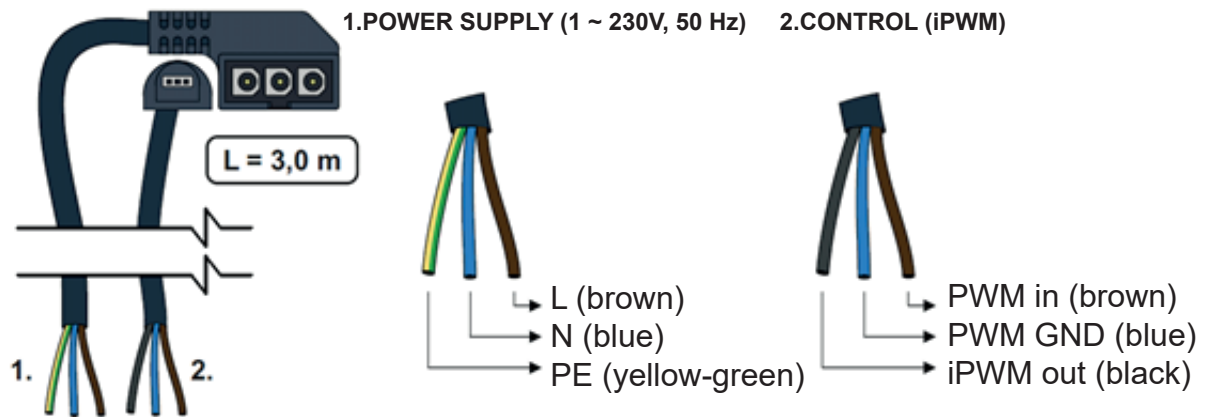





## 4.4. Technical Data

Wilo PARA 25/8 iPWM1	
<b>Electric Data</b>	
Electric Data	230 V, 50 Hz
Power input (min./max.)	2 / 75 W
Current (min./max.)	0.03 / 0.66 A
Max. speed	4800 pm
Speed control	frequency converter
Energy Efficiency Index	≤ 0,21 by EN 16 297/3
IP rating	IPX4D
Motor protection	integrated
<b>Min. pressure at the suction port to avoid cavitation</b>	
Min. pressure at the pump suction port	0.5 mH <sub>2</sub> O at 50 °C
	4.5 mH <sub>2</sub> O at 95 °C
<b>Operating Parameters</b>	
Fluid working temperature	0 - 95 °C
Max. static pressure	10 bar
Max. head	8.4 m

## 4.5. FAULTS AND THEIR REASONS

 The LED light signals a defect. The pump will switch off (depending on the defect type) and try to restart.

LED signals	State description and possible fault reasons
	GREEN IS LIT 1 - pump is running in trouble-free operation
	RED IS LIT 1 - rotor is blocked 2 - electric motor winding defect
	FLASHING RED 1 - power supply lower/higher than 230 V 2 - electric short circuit in pump 3 - pump overheated
	FLASHING RED AND GREEN 1 - unforced fluid circulation through the pump 2 - pump speed lower than desired 3 - air in pump

If the fault cannot be rectified, contact a qualified technician.

## 4.6. Performance curves for Wilo Para 25/8 iPWM1 pump

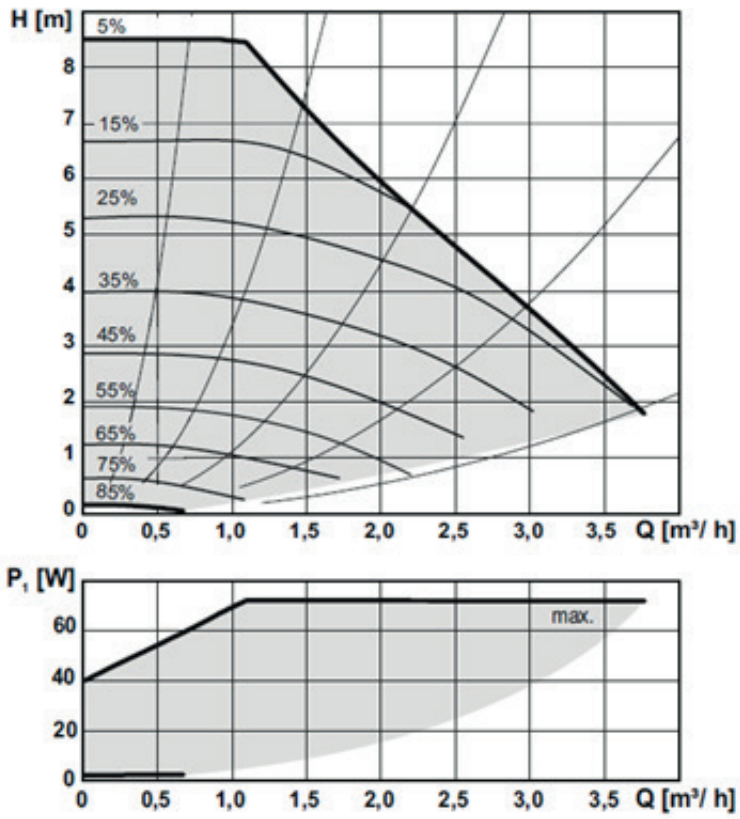

## 5. Ball Valve w. filter & magnet



### 5.1. Maintenance and cleaning

1. Close the ball valve by turning the lever clockwise by 90° (Fig. 1).
2. Unscrew the lid with magnet manually and take out the strainer (Fig. 2, 3).
3. Remove impurities from the strainer and magnet.
4. Return the clean strainer back to its place and screw on the lid with magnet.
3. Open the ball valve by turning the lever counter-clockwise by 90° (Fig. 4).



fig. 1

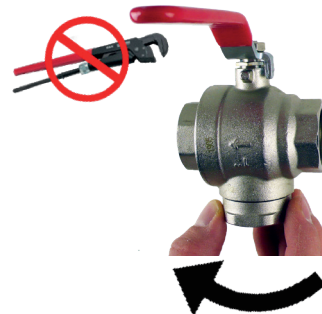

fig. 2



fig. 3

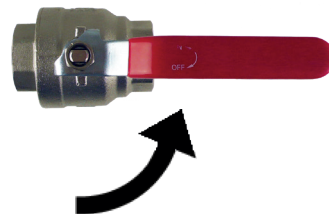

fig. 4

