



[www.regulus.eu](http://www.regulus.eu)



ETT-U Heating Element

Installation and Operation Manual  
Heating Element with Thermostatic Head

EN

**ETT-U Heating Element**

# 1 - General Information

## 1.1 - Application

The electric heating element is intended for DHW heating in a hot water storage tank or for heating of heating water in thermal stores of a heating system. The element is suitable for utilizing surpluses from single-phase and three-phase photovoltaic systems.

## 1.2 - Installation

Screw the electric heating element into the appropriate connection (socket) equipped with a G 6/4" F thread. For sealing, we recommend using sealing yarn, hemp, Teflon tape or thread sealant allowing disassembly.

A cable for connection to a terminal box or electrical switchboard is included in supply.

## 1.3 - Maintenance

Clean the exterior of the heating element with a soft cloth and a suitable detergent. Never use abrasive cleaners or solvents.

If the element is used in extra hard water, it is recommended to remove sediments at least once a year. Disconnect the element from the mains before cleaning. Then drain water from the tank and dismount the heating element. Scratch the hard deposits on the heating rod with a plastic or wooden spatula and flush with water. Be careful not to damage the protective nickel layer on the heating rod. Then reinstall the body according to this instruction manual, fill the tank with water, air-bleed and pressurize it. Check the threaded connection for leaks. Finally, reconnect the heating element to the mains.

## 1.4 - Disposal

### **IMPORTANT INFORMATION ON PROPER DISPOSAL OF E-WASTE AS REQUIRED BY THE EC DIRECTIVE 2002/96/EC (WEEE)**

Do not dispose of this product as unsorted municipal waste. Please dispose of this product by returning it to the point of sale or to your local municipal collection point for recycling.

Respecting these rules will help to preserve, protect and improve the quality of the environment, protect human health and utilize natural resources prudently and rationally.

The crossed out wheeled bin with marking bar, printed either in the Manual or on the product itself, identifies that the product must be disposed of at a recycling collection site.



WEEE Registration Number: 02771/07-ECZ

# 2 - Heating Element with Thermostatic Head

## 2.1 - Technical description

The electric heating element consists of a nickel-plated heating rod with G 6/4" M thread, a combined 3-phase capillary thermostat (the operating thermostat is adjustable between 15 °C and 80 °C - the upper limit is set to 60 °C for use in hot water tanks, the manual reset safety thermostat set to 99 °C fixed temperature), and a 2m power cable for a fixed connection to a terminal box or electrical switchboard.

Technical Data	
Electrical wiring	1/N/PE AC 230 V 3/N/PE AC 400/230 V
IP rating by EN 60529	IP 54
Protection class by EN 61140 ed. 2	I
Body type	electric, resistive, nickel-plated, with thermostatic head
Adjustable thermostat	adjustable from 15 +/- 5 °C to 80 +/- 5 °C
Safety thermostat	fixed temp. at 99 +/- 6 °C
Safety thermostat reset	manual, after temperature drop by 10 K min.
Max. current at thermostat contacts	20 A
Cable gland	Pg 13
Connection thread	G 6/4"M outside
Connection to mains	cable for a fixed connection to a terminal box or electrical switchboard, 2m long.

## 2.2 - Dimensions

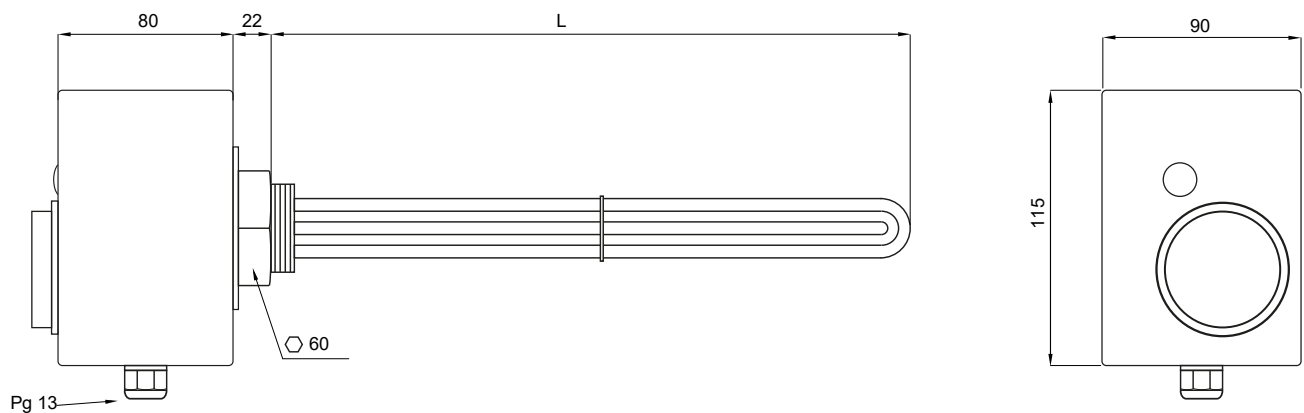

Element type	Nominal output	Element length L [mm]	Non-heating end length [mm]	Power cable (L=2m)	Code
ETT-U - 2,0	2,0 kW	310	180	5x1,5	20214
ETT-U - 3,0	3,0 kW	370	180	5x2,5	20220
ETT-U - 5,0	5,0 kW	500	180	5x2,5	20216
ETT-U - 6,0	6,0 kW	555	180	7x1,5	20219

### 2.3 - Connection to the mains

The electric heating element shall be wired to a terminal box or electrical switchboard, 3/N/PE AC 400/230V, fixed wiring, using the cable included in supply. The installation shall meet valid rules and standards and shall be done by an authorized person only.

### 2.4 - Wiring Diagram

- for 2-, 3- and 5kW heating elements

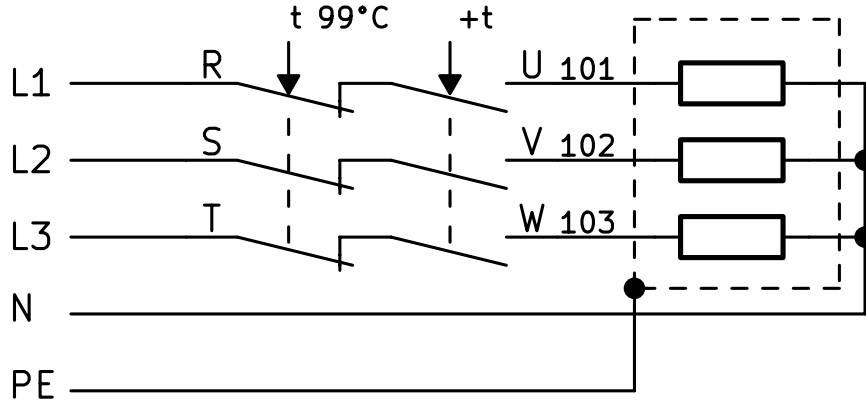

- for 6kW heating element

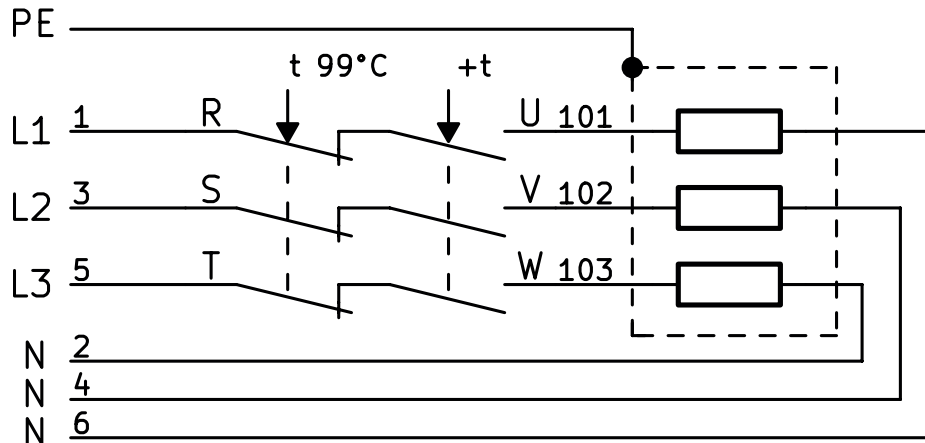

### 2.5 - Commissioning, Operation and Possible Faults

#### WARNING!

**THE OUTGOING HOT WATER SHALL NOT BE LEAD THROUGH COMMON PLASTIC PIPES. THE PIPING SHALL BE RESISTANT TO TEMPERATURE OF 100 °C MIN. IF PLAIN COMMON PLASTIC PIPING IS USED, ITS SERVICE LIFE IS SIGNIFICANTLY REDUCED UNDER TEMPERATURES OVER 60 °C. WHEN COMBINED WITH IMPROPER PIPE FIXING THAT RESTRICTS DILATATION OR EVEN MAKES IT IMPOSSIBLE, THE PIPE SERVICE LIFE MIGHT BE JUST SEVERAL HOURS!**

Prior to commissioning, please make sure the water in direct contact with the heating element does not exceed the values given in the table below. The manufacturer bears no responsibility for defects (e.g. limescale deposits on the heating element) caused by adverse operating conditions.

**Table of limit values for total dissolved solids in hot water**

Description	pH	Total Dissolved Solids (TDS)	Calcium	Chlorides	Mg	Na	Fe
max. value	6,5-9,5	600 mg/litr	40 mg/litr	100 mg/litr	20 mg/litr	200 mg/litr	0,2 mg/litr

### 2.5.1 - DHW heating in a hot water storage tank

In order to heat water in the hot water storage tank, open the cold water inlet, fill the tank with water and airbleed it by opening the hot-water tap. Set the thermostat knob to the desired temperature.

It is recommended to set the thermostat knob to 60 °C. This temperature guarantees the best operation of the heating element and at the same time, it offers:

- protection against Legionella
- cost reduction
- slower deposit formation

### 2.5.2 - Heating water for space heating in a thermal store

Fill the heating system with heat transfer fluid, air-bleed it and pressurize to the working pressure. Set the thermostat knob to the desired temperature.

If you wish to set a higher temperature than 60 °C, the limiting spring under the knob needs to be removed.

#### Instructions:

Remove the knob from the thermostat shaft.

The limiting spring inside the knob is inserted in the groove 1 (see fig.) which limits the set temperature to 60 °C. Take out this spring and refit the knob onto the thermostat shaft.

This modification will increase the thermostat adjustment range to 15-80 °C.

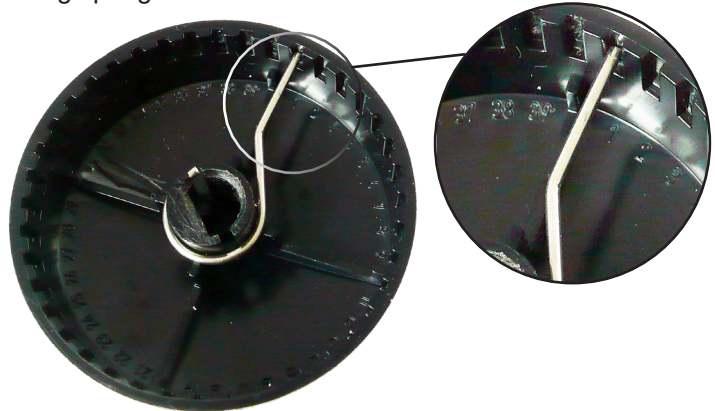

### 2.5.3 - Possible faults

When the safety temperature is reached, the safety thermostat disconnects the heating element from the electricity supply. The safety thermostat features no automatic reset. After the tank temperature drops by min. 10 K pry off the white plastic cap (see picture) with a screwdriver, press the button and click the cap back. Repeated occurrence of this condition indicates a failure of the heating element. In such a case, disconnect the heating element from mains and call a service technician.



If the heating element shows signs of another defect, disconnect it from the mains immediately and call a service provider.



# WARRANTY CERTIFICATE

## *Heating Element with Thermostatic Head*

Type: .....

Serial number: .....

Shop: .....

Purchase date: .....

### WARRANTY CONDITIONS

1. The warranty period is 24 months from the date of purchase.
2. The product will be installed and commissioned by a competent company or a person trained by the manufacturer.
3. When claiming warranty, this Warranty Certificate must be submitted together with the purchase receipt.
4. The warranty is valid only when the technical conditions set by the Manufacturer, installation manual and instructions in the documentation and on the product itself are maintained.
5. The warranty does not cover defects caused by external conditions or improper operation conditions, defects caused by usual wear and tear, further when the product is not used in compliance with its purpose and when the defect was caused by mechanical damage, improper handling, tampering by a third person, improper installation, improper stocking, natural disaster etc.

### COMMISSIONING

Company: .....

Date: .....

Rubber stamp print and signature of the installer:

