



**mut = meccanica tovo** S.p.A.

Via Bivio S. Vitale, 36075 Montecchio Maggiore (VI) ITÁLIE

## 3-WAY ZONE VALVE WITH ACTUATOR



The valve meets the basic requirements of the following Directives:  
73/23/EC Low Voltage Directive  
89/336/EC Electromagnetic Compatibility

**SERIES  
VMR**

### General Information

This User's Guide is not a complete description of the valve nor a detailed illustration of how it works. Users, however, will find here all they normally need to know, how to use the valve safely.

Valve selection is done based on its technical and hydraulic characteristics. The valves shall be oriented as shown in Pic. 1, 2 and 3. Outlet paths are indicated on the body of the valve itself. Packing and all that is inside the packing (plastic bags, polystyrene etc.) must be kept out of the reach of children as they are potential sources of danger if ingested.

The product must be stored in such environment where it is protected against dust and humidity. Failure to respect the instructions given in this Guide, negligence or poor and mistaken use of the valve will invalidate warranty and relieve the Manufacturer for any damage caused by it.

The Manufacturer guarantees its products for a period of 12 months from the date of manufacture. Warranty coverage consists exclusively of free of charge repair or replacement of those parts that are found defective after a thorough examination by the engineering Office of the Manufacturer. The Warranty, which excludes any responsibility for direct and indirect damage, is limited exclusively to defects in materials and becomes null and void whenever the parts that are returned are found to have been dismantled, tampered with or repaired outside the Manufacturer's premises. Material that is returned, even if it is under Warranty, must be sent back carriage free. Removal of the safety devices mounted on the valve automatically terminates the Warranty and the Manufacturer's responsibility.

Each valve has an identification label that indicates:

- name and address of the Manufacturer
- EC marking - indication of series or type
- possibly serial (lot) number
- year of manufacture
- main technical data

It is forbidden to use the valve in machines/systems before these have been declared to comply with EEC Machine Directive 89/392 and subsequent modifications. After its lifetime expires, the valve can be sent back carriage free to the Manufacturer.

### Information prior to Installation

The valve must be installed in systems that are compatible with its characteristics. Before connecting it to the system check that:

- system pipelines have been thoroughly cleaned to eliminate all residue
- the axes of paths A and B in the valve body are at least 125 mm from external restraints that could make it difficult or impossible to perform repairs that require disassembly of valve components
- the valve is not installed upside down, i.e. with the servomotor facing down
- electrical power is as indicated on the valve box
- pressure in the plumbing mains and the pressure difference between paths A and B or AB is suitable for valve operation (see Technical Characteristics)

### Proceed as follows for correct installation:

- remove the electric actuator, press the block push-button and rotate the actuator itself counterclockwise (looking at the cover). Install the valve body in the plumbing system without applying force on the gate shaft that exits from the valve body
- reinstall the actuator: insert it in the specific hooks on the valve body and rotate it clockwise until it is blocked in place

### Warning: before start-up

The valve must be connected to an external control (thermostat etc.) using the 3-wire cable and respecting phases and neutral. Make sure label data correspond to those for the power supply. A standardized „A05 VVF 0.75“ cable must be used if the supply cable must be replaced.

**Power supply: disconnect the mains before starting any work on the electric system.**

No. of microswitches installed	with cable		with Molex™	
	none	M1S	none	M1S
C common	/	green		1
NO normally open	/	orange	/	4
NC normally closed	/	red	/	5
<b>Motor supply</b>				
(N) neutral	blue	white	2	2
(L) Line path A open: Pic. 2)	brown	gray	3	3
(L) Line path A open: Pic. 1)	black	black	6	6

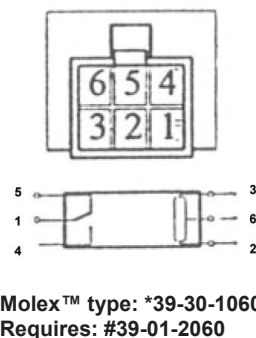

### Auxiliary Switches:

All versions are also available with an auxiliary microswitch. This is actuated by valve opening or closing movements through a cam. Microswitch contacts are independent from the valve's electric circuit. Versions are available with a 2-pole microswitch (version M1S). M1S microswitches cannot be installed on valves where they are not originally installed.

### Materials:

Valve body	bronze	Actuator cover	self-extinguishing ABS;
Motor bracket	PBT resin	Gate stem	stainless steel
Cylindrical gate	POM resin	Static and dynamic gaskets	EPDM;
Return spring	steel	Inner sleeve	PA resin

**Manual Lever:**

A lever, located on the side of the servomotor, is used to manually position the valve stem in an intermediate position (Pic. 3).

The manual lever can only be manipulated when it is in its upper position.

The valve can be opened by firmly pressing the manual lever both down and in until it locks in the intermediate position. Paths A and B are open in this position.

This is useful when filling or emptying the pipeline system or when there is a power failure.

The lever is automatically reset from manual to automatic whenever the valve is activated by a return of electric power.

**Regular Maintenance Instructions:**

No valve maintenance is required whenever the pipeline system is not in use.

No special cleaning or maintenance procedures are necessary except for replacement of parts that are subject to wear. Check that the electricity supply cable is intact.

To clean or replace the inner cartridge be sure first to interrupt electrical power and make sure the valve is isolated from the pipeline system. Turn to a Technical Service Center whenever problems arise.

**Technical Characteristics:**

Auxiliary contact capacity:	3 A, 250 V A.C.;
Rated pressure PN:	10 kg/cm <sup>2</sup>
Flow temperature limits:	5-110 °C;
Path switching time:	6 s:
Nominal voltage:	220-240 V AC, 50/60 Hz
Protection:	IP 40; EC 529; Standards, European Standards Reference CEI EN 60529.
Maximum pressure differential:	4 kg/cm <sup>2</sup>
Maximum room temperature:	60 °C
Power input:	4 W
Total length of standard cable:	650 mm

**Operation:**

All moving parts and seals are assembled in a cartridge. Hermetic path seal is guaranteed by O-rings on the outer surface of the piston. When the valve stem is in its lowered position, closing path B, flow takes place through paths A and AB, passing through the holes in the cylindrical gate (Pic. 1). When, on the other hand, the stem is in its raised position, the flow is blocked in path A and goes through paths A and AB (pic. 2). Switchover from one path to the other takes place in about 6 seconds.

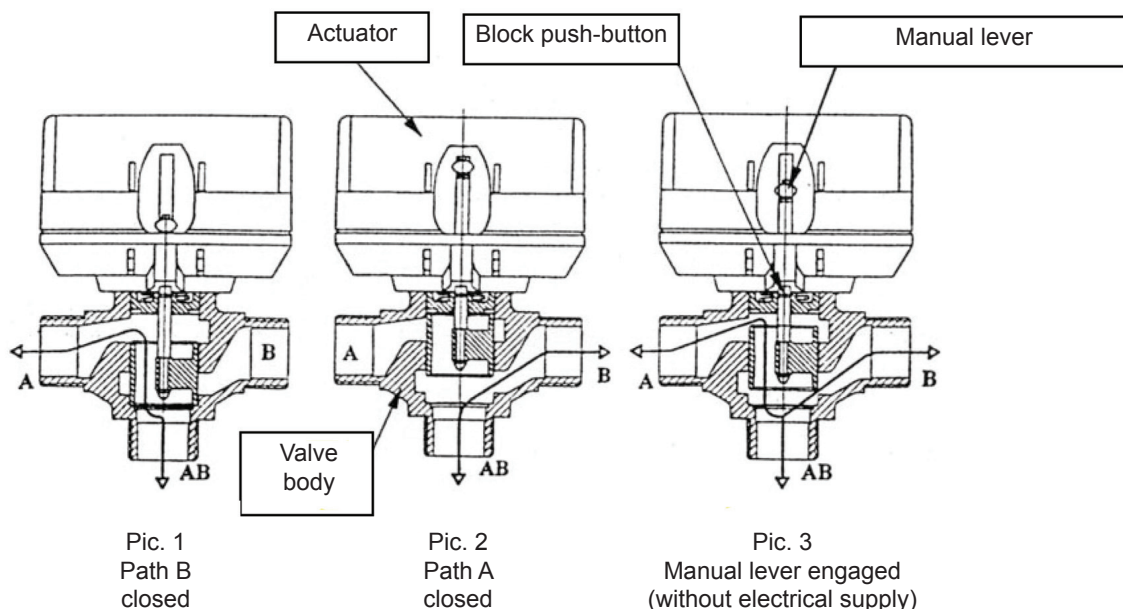

## Overall dimensions

These valves are furnished with path **A** normally closed (without electrical supply, see Pic. 1), where the shut-off ball closes path **A** because of the elastic force exercised by the return springs. When the electrical supply is activated, the servomotor overcomes the force of the springs and moves the ball from path **A** to an intermediate position in about 10 sec. It maintains the ball in that position until the electrical supply is interrupted (Pic. 2). When the electrical supply is interrupted, the return springs shift the valve back on path **A** in about 4 s.

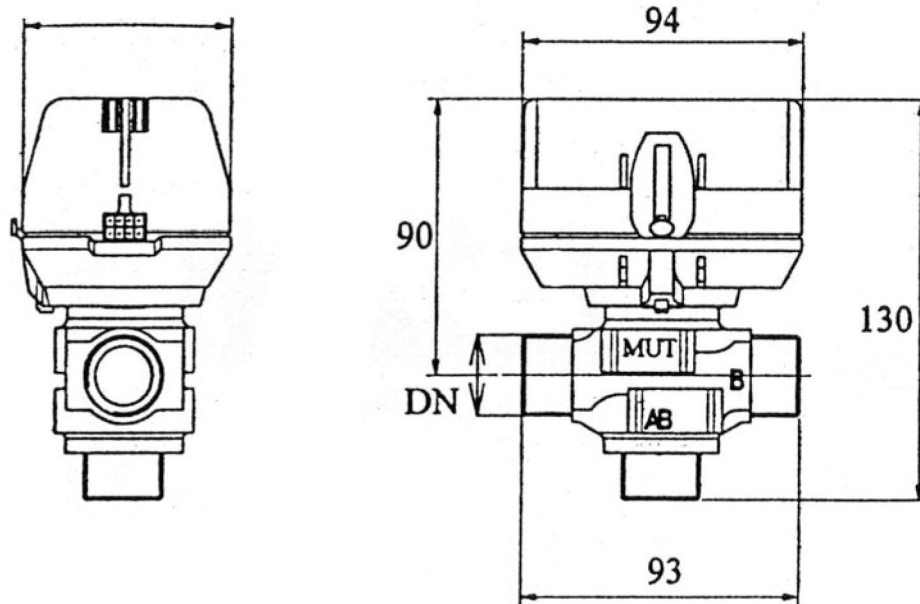

DN, GV (UNI ISO 228/1)

## Electrical Connections:

these are illustrated in Pics 5 and 6. There are two types of electrical connections depending on the type of low voltage of the external control unit:

- 2-pole 3-wire SPDT (3 wire) external control: when hot water is requested, the control unit (SPDT) closes the NO contact, the valve closes path B and opens path A. When path A is totally open, the camshaft closes travel limit microswitch C1 and opens travel limit microswitch C2. When hot water is no longer requested, the control unit closes the NC contact, supplying the valve through C1 and causing closure of path A. When path A is totally closed, the cam closes microswitch C2 and opens microswitch C1. The valve is now ready for the next request for hot water.
- Single-pole 2-wire SPST (2 wires and common) external control: when hot water is requested, the control unit (SPST) closes contact N that supplies the relay that in its turn closes the NO contact (microswitch C3). This causes closure of path B and aperture of path A. When path A is totally open, the cam closes microswitch C1 and opens microswitch C2.

When hot water is no longer requested, the control unit opens contact N. At this point the relay is no longer powered and the NC contact (microswitch C3) is closed. This causes closure of path A and aperture of path B. When path A is totally closed, the cam closes C2 and opens C1. The valve is now ready for the next request for hot water.

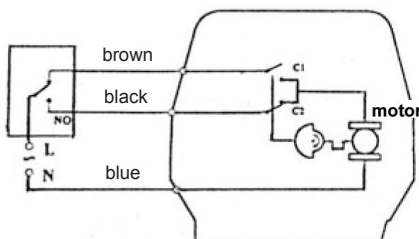

Pic. 5 - SPDT control

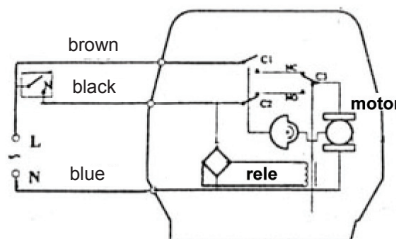

Pic. 6 - SPDT control

N.B. In both cases an interruption of the power supply will leave the valve in the position it was in at the moment the power was interrupted.