

OV-3/8 BV-ZV Air Vent Valve

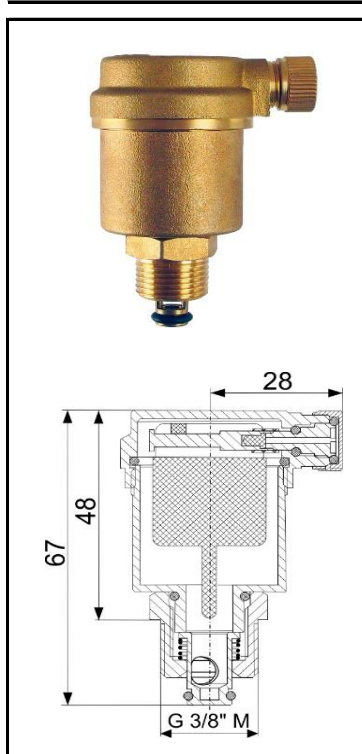

Main Features

Description	The automatic air vent valve is designed to remove air from heating systems. It comes with a check valve that permits to replace the air vent valve without draining the heating system.
Working fluid	water; water/glycol mixture (max. 1:1) or water/glycerine mixture (max. 2:1)
Installation	at the highest point of a heating system; only vertically with the cap upwards
Code	18905

Technical Data

max. working temperature	110 °C
Max. working pressure	10 bar
Total weight	120 g
Connection	G 3/8" M

Materials

Housing	brass
Cap	brass
Seal	EPDM
Cap spring	stainless steel