

## BOILER PROTECTION AGAINST OVERHEATING

### One-way Thermal Relief Valves



#### JBV1 Thermal Relief Valve

A thermal relief valve designed for cooling solid-fuel boilers **with a cooling heat exchanger**. When the temperature reaches 97°C, the valve opens and lets cold water in from the mains that it cools the boiler down **via a cooling heat exchanger**, preventing its overheating. Hot water is discharged into a sewer.

In order to work properly, the valve shall be installed in a place where the highest temperature is reached in case of overheating - usually directly in a top section of the boiler or in an outlet pipe close to the boiler.

The thermostatic element from a renowned French manufacturer is located directly in heating water, so its **reaction to heating water temperature fluctuations is almost immediate**. The valve has no capillary that could get damaged during installation. The valve has a push button for manual opening (like safety valves).

Functional tests are performed on each valve in production.

#### Technical Data

OPENING TEMPERATURE	97 ± 2 °C
MAX. WORKING PRESSURE - HEATING WATER	4 bar
MAX. WORKING PRESSURE - COLD WATER	6 bar
PIPE CONNECTION	G 3/4" M
HEAT SOURCE CONNECTION	G 1/2" M
WEIGHT	0.70 kg
CODE	8 877

The valve is patented in many European countries.



#### Dimensions

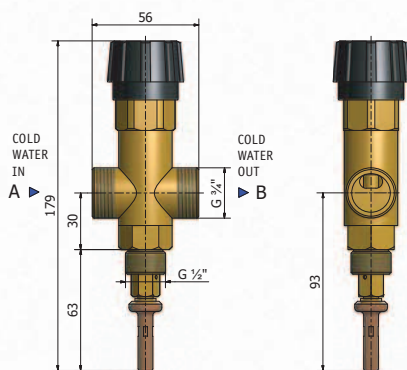

#### Connection in a system

