

THREE-WAY ZONE VALVES

LK525 Three-way Zone Gate Valve

Zone gate valves intended for heating or solar thermal systems with water or antifreeze fluid.

The valve is equipped with a **two-point control actuator (SPST)**. It comes with a 1m long 3-wire power cable. The valve must not be installed in a position with the actuator facing down.

A working neutral, a permanent phase and a control phase must be supplied to the valve. Without the control phase, the outlet B is open, after the control phase is applied, the outlet A opens. **Shift time is 8s.**

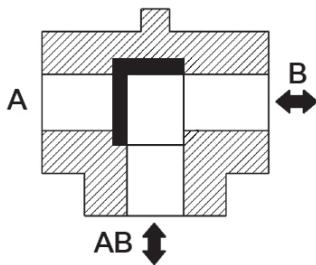

TECHNICAL DATA

MAX. WORKING PRESSURE	10 bar
MAX. PRESSURE DIFFERENCE	10 bar
FLUID WORKING TEMPERATURE	5 to 80 °C (120 °C with extension - code 11278)

MATERIALS

VALVE HOUSING	brass, forged
VALVE MEMBER	PPS composite
VALVE SPINDLE	PPS composite
POWER CABLE	PVC

ACTUATOR

POWER SUPPLY	230 V 50 Hz
POWER INPUT	7 W
CURRENT	30 mA
IP RATING BY EN 60529	IP 40
PROTECTION CLASS BY EN 61140 ed.2	II

POWER CABLE

CROSS SECTION	3× 0.75 mm ²
LENGTH	1 m

VALVE PRESSURE DROP

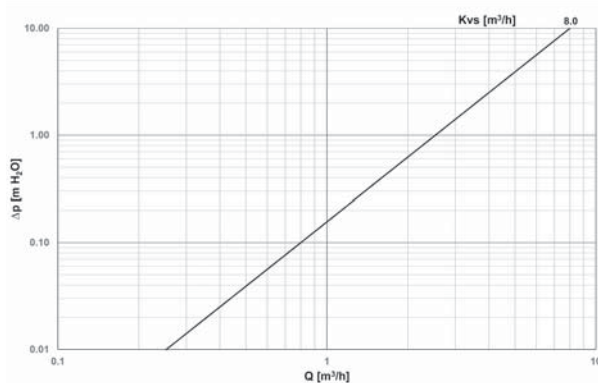

DIMENSIONS AND TYPES

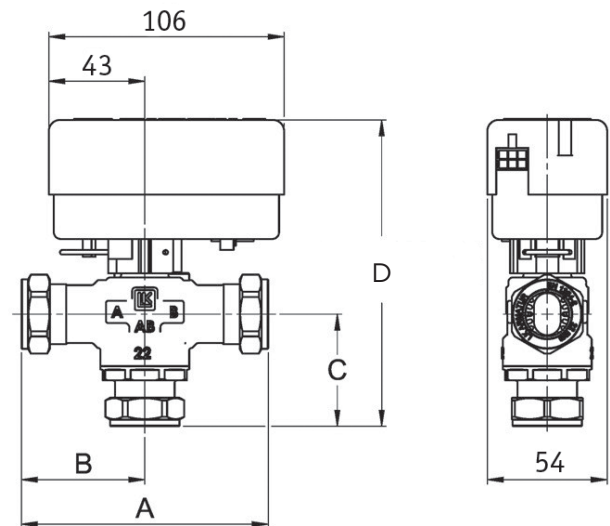
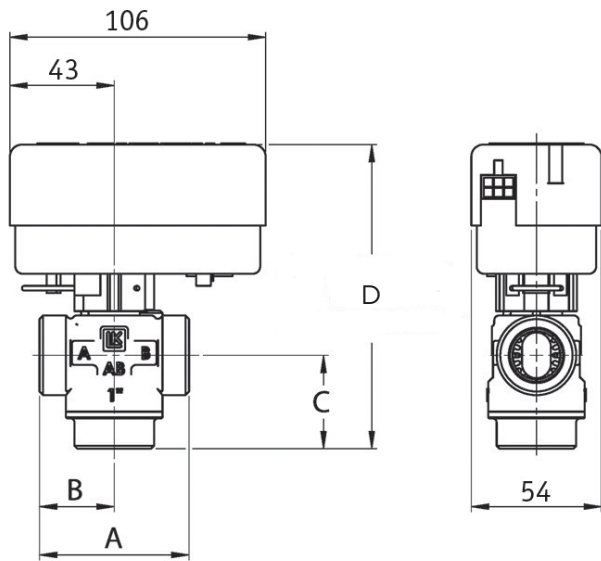

CONNECTIONS	--	1" M	5/4" M	Cu22	Cu28
A	mm	62	74	110	110
B	mm	31	37	55	55
C	mm	39	40	50	54
D	mm	127	128	138	142
WEIGHT	kg	0.6	0.6	0.4	0.6
MAX. PRESSURE DIFFERENCE	bar	10	10	10	10
KVS	m ³ /h	8.0	8.0	8.0	8.0
CODE	--	11284	11285	14883	14884

ELECTRICAL WIRING

