

TWO-WAY ZONE VALVES

VZK M Two-way Zone Ball Valve

Zone ball valves intended for heating or solar thermal systems with water or antifreeze fluid and for drinking water systems. The valve is equipped with a lever for manual control.

An electric actuator can be retrofitted to the valve - see page 40.



TECHNICAL DATA

MAX. WORKING PRESSURE	10 bar
MAX. PRESSURE DIFFERENCE	10 bar
FLUID WORKING TEMPERATURE	up to 110 °C

MATERIALS

VALVE HOUSING	CW617N
VALVE SPINDLE	CW617N
VALVE BALL	chrome-plated brass
O-RINGS	EPDM, FPM

VALVE PRESSURE DROP

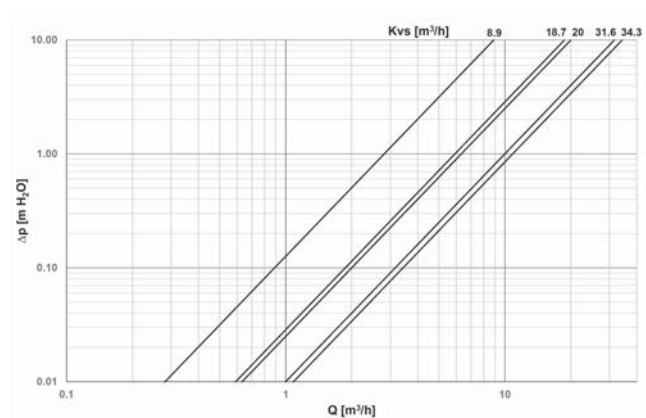

DIMENSIONS AND TYPES

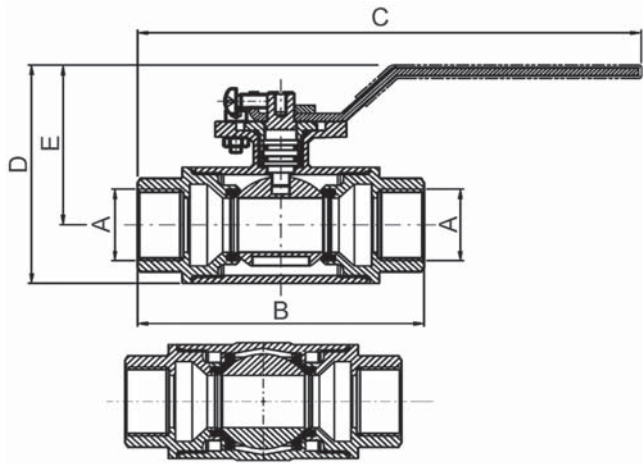

		VZK M 220 1/2F	VZK M 220 3/4F	VZK M 220 1F	VZK M 225 1F	VZK M 225 5/4 F
CONNECTIONS	--	1/2" F	3/4" F	1" F	1" F	5/4" F
B	mm	96	96	96	104	104
C	mm	170	170	170	174	174
D	mm	81	81	81	90	90
E	mm	55	55	55	64	64
WEIGHT	kg	0.7	0.7	0.7	1.0	1.0
NOMINAL DIAMETER	DN	20	20	20	25	25
KVS	m ³ /h	8.9	18.7	20.0	31.6	34.3
CODE	--	20018	20021	20016	20023	20020