



www.regulus.eu



THERMAL STORES PS E+

Installation and Operation Manual
THERMAL STORES

EN

PS 500 E+, PS 750 E+, PS 1000 E+, PS 1100 E+ and PS 1250 E+



THERMAL STORES PS E+

CONTENTS

1 Description	3
1.1 Models	3
1.2 Tank protection	3
1.3 Thermal insulation	3
1.4 Connection points on the tank	3
1.5 Packing.....	3
2 General Information	3
3 Technical Data and Dimensions	4
4 Operation.....	7
5 Typical Installation Examples	7
6 Installation and Commissioning	8
7 Installing Insulation on the Tank	9
8 Maintenance.....	11
9 Disposal	11
10 Warranty	11

1 - Description

PS E+ Accumulation Tanks are intended for accumulation and subsequent distribution of thermal energy from solid-fuel fired boilers, heat pumps, solar collectors, electric boilers etc. No heating coils can be installed into these tanks, just an el. heating rod. Heating rods of 2-12 kW output can be installed directly into the 6/4" sleeves that are power supplied either with 230V or 3x230V/400V. Tanks are fitted with four side sleeves, one top sleeve and two sleeves for sensor sheaths. 100mm thick insulation for these tanks is sold separately.

1.1 - Models

Five models of 473 l, 756 l, 927 l, 1038 l and 1260 l capacity.

1.2 - Tank protection

The inner surface has no finish, no anticorrosion protection, the outer surface is lacquered in gray.

1.3 - Thermal insulation

Tank insulation is available as a separate item, installed on the tank on the spot for easier handling. The insulation is made of 100 mm thick fleece and fitted with a zippered outer PU leather jacket.

1.4 - Connection points on the tank

4 side sleeves, G 6/4" F

1 top sleeve, G 6/4" F

2 side sleeves for sensor sheaths, G 1/2" F

1.5 - Packing

Tanks are delivered standing, each screwed to its pallet, packed in bubble wrap.

2 - General Information

This Owners Manual is an integral and important part of the product and must be handed over to the User. Read carefully the instructions in this Manual as they contain important information concerning safety, installation, operation and maintenance. Keep this Manual for later reference. The appliance shall be installed by a qualified person according to valid rules and Manufacturer's Instructions.

This appliance is designed to accumulate heating water and distribute it subsequently. It shall be connected to a heating system and heat sources.

Using the accumulation tank for other purposes than above described is forbidden and the manufacturer accepts no responsibility for damage caused by improper or wrong use. The accumulation tank shall not be used as a DHW tank!

The appliance shall be installed by a qualified person according to valid rules, otherwise the warranty becomes null and void.

3 - Technical Data and Dimensions

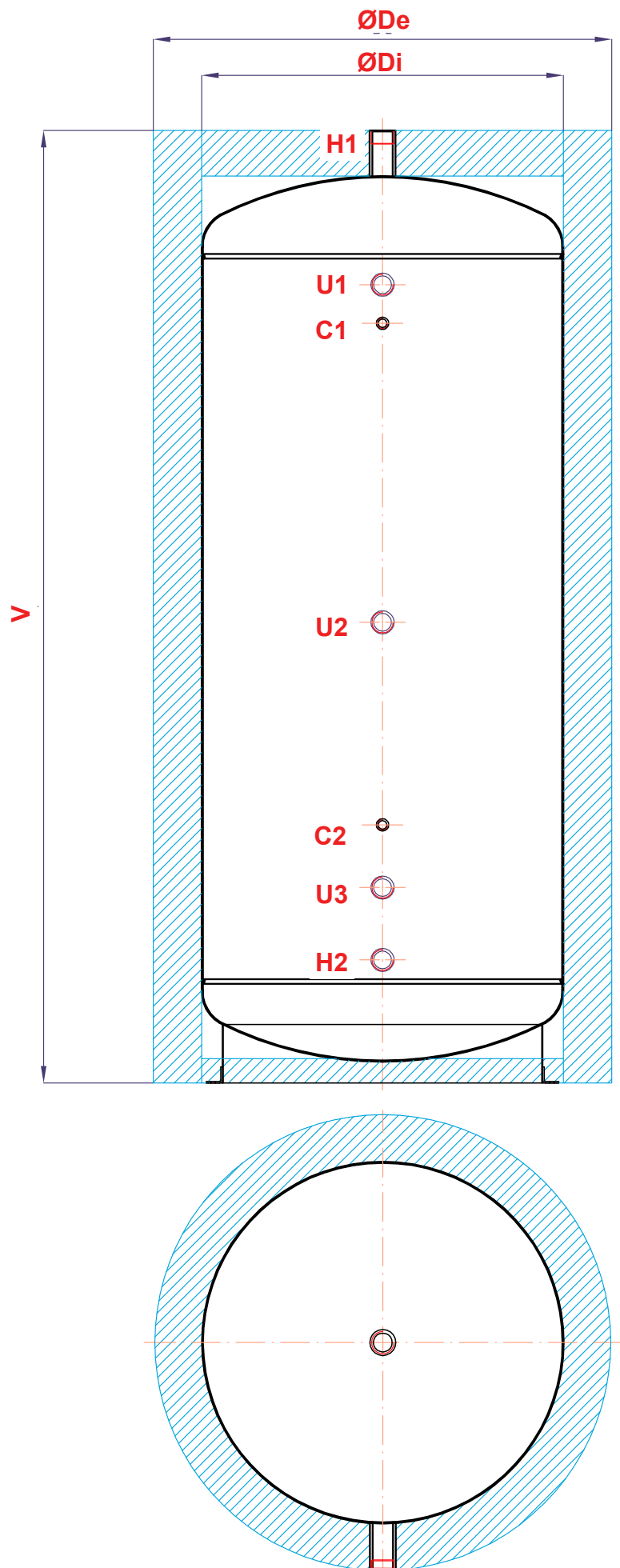

Code											
Thermal Store	PS 500 E+	PS 750 E+	PS 1000 E+	PS 1100 E+	PS 1250 E+						
Tank code	14 754	15 212	15 851	15 215	15 992						
Insulation code (accessory)	16 330	16 338	16 344	16 347	16 351						
Application											
Storing and subsequent distribution of heat from solid fuel boilers, heat pumps or other heat sources.											
Energy Efficiency (EC Regulation 812/2013)											
	PS 500 E+ with insulation	PS 750 E+ with insulation	PS 1000 E+ with insulation	PS 1100 E+ with insulation	PS 1250 E+ with insulation						
Energy Efficiency Class	C	-	-	-	-						
Storage volume	92 W	118 W	131 W	139 W	156 W						
Storage volume	473 l	756 l	927 l	1038 l	1260 l						
Technical Data											
Total tank volume	473 l	756 l	927 l	1038 l	1260 l						
Max. working temperature in tank	95 °C	95 °C	95 °C	95 °C	95 °C						
Max. working pressure in tank	4 bar	4 bar	4 bar	4 bar	3 bar						
Material											
Tank material	S235JR	S235JR	S235JR	S235JR	S235JR						
Dimensions, tipping height, weight											
Tank diameter	600 mm	750 mm	800 mm	850 mm	950 mm						
Tank diameter with insulation	800 mm	950 mm	1000 mm	1050 mm	1150 mm						
Total tank height	1915 mm	1975 mm	2080 mm	2080 mm	2065 mm						
Tipping height without insulation	1940 mm	2020 mm	2120 mm	2130 mm	2120 mm						
Max. length/output of heating el.	680 mm / 9 kW	755 mm / 9 kW	815 mm / 12 kW	815 mm / 12 kW	955 mm / 12 kW						
Empty weight	68 kg	90 kg	106 kg	124 kg	125 kg						
Accessories											
Insulation	code 16330	code 16338	code 16344	code 16347	code 16 351						
Safety valve	3 bar, 1/2" M-F, included										
El. heating element	models ETT-A, C, D, E, F, G, K, L										
Thermal Store		PS 500 E+	PS 750 E+	PS 1000 E+	PS 1100 E+	PS 1250 E+					
Tipping height without insulation		1940 mm	2020 mm	2120 mm	2130 mm	2120 mm					
Marking		Conne- ction	Height [mm]	Conne- ction	Height [mm]	Conne- ction	Height [mm]	Conne- ction	Height [mm]	Conne- ction	Height [mm]
Heating system											
H1		G 6/4"	1915	G 6/4"	1975	G 6/4"	2080	G 6/4"	2080	G 6/4"	2065
H2		G 6/4"	225	G 6/4"	225	G 6/4"	300	G 6/4"	255	G 6/4"	300
Control, safety											
C1		G 1/2"	1545	G 1/2"	1575	G 1/2"	1620	G 1/2"	1665	G 1/2"	1620
C2		G 1/2"	505	G 1/2"	535	G 1/2"	580	G 1/2"	535	G 1/2"	580
Universal inlet/outlet											
U1		G 6/4"	1625	G 6/4"	1655	G 6/4"	1700	G 6/4"	1745	G 6/4"	1700
U2		G 6/4"	975	G 6/4"	955	G 6/4"	1050	G 6/4"	1045	G 6/4"	1000
U3		G 6/4"	375	G 6/4"	405	G 6/4"	450	G 6/4"	405	G 6/4"	450
Tank dimensions [mm]											
V - Tank height		1915		1975		2080		2080		2065	
Ø Di - Tank diameter		600		750		800		850		950	
Ø De - Diam. with insulation		800		950		1000		1050		1050	

4 - Operation

In the accumulation tank heating water is heated up from several heat sources like various types of hot-water boilers, renewable energy sources (heat pumps, solar collectors), or electric heating rods.

The accumulation tank shall be connected to a heat source through G 6/4" threaded fittings. Should the tank be connected to a solar system, this must be done via a heat exchanger because solar systems are not filled with heating water. Individual connection points are assigned according to the circuits to be connected. There is a wide choice of combinations, just some examples are described in the following chapter.

5 - Typical Installation Examples

Example I.

Solid fuel boiler and el. heating rod.

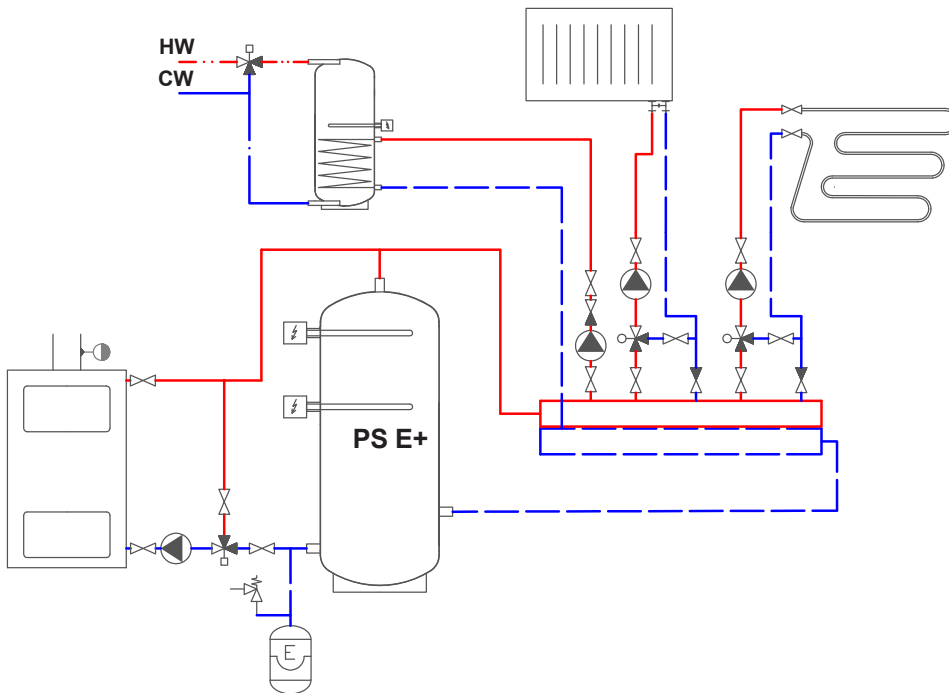

Example II.

Gas fired boiler and hydronic fireplace.

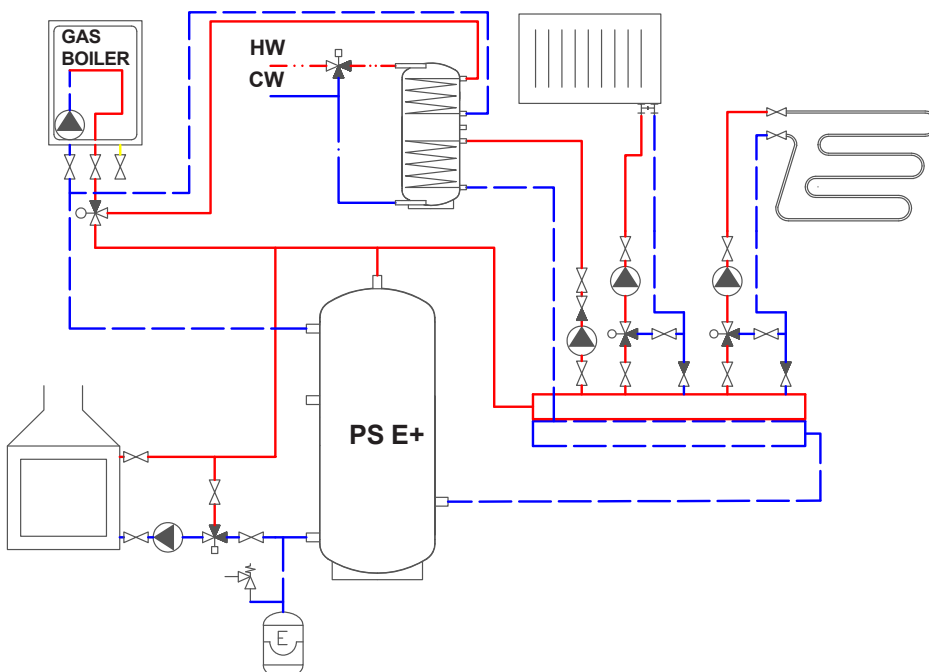

6 - Installation and Commissioning

Defects caused by improper installation, use or handling are not covered by warranty.

Defects caused by improper installation, use or handling are not covered by warranty.

After the tank is installed and connected to an existing heating system, it is recommended to clean the entire heating system using a suitable cleaning agent, e.g. MR-501/R or some other supplied by Regulus.

Anti-corrosion protective liquid should be also used, e.g. MR-501/F or F1.

6.1 - Connection to heat sources

Place the tank on the floor, as close to your heat source as possible. Mount the insulation, cf. Installing Insulation on the Tank. Connect the heating circuits to inlets and outlets respecting the thermal stratification in the tank. Install a drain valve at the lowest point of the tank. Install an air vent valve at the highest point of the system. Insulate all the connecting piping.

6.2 - Connection to a solar system

The tank can is not primarily intended for use with a solar system but if needed, this can be done via a heat exchanger between the solar system and the tank. In such a case, insulate well all the piping between the tank and the solar system.

6.3 - Heating rod installation

The tank may be fitted with electric heating rods up to 9 kW (12 kW) output. They can be power-supplied either directly (elements with built-in thermostat) or via a controller for the entire heating system.

All electric heating elements shall be protected by a safety thermostat.

Electric heating rods shall be installed by an authorized person only.

6.4 - Commissioning

This tank is not designed for DHW heating.

The tank shall be filled up together with the heating system, respecting valid standards and rules. In order to minimize corrosion, special additives for heating systems should be used. The quality of heating water depends on the quality of filling water at commissioning, on the top-up water and on the frequency of topping up. This has a strong influence on the lifetime of heating systems. Poor quality of heating water may cause problems like corrosion or incrustation, esp. on heat transfer surfaces.

Fill the heating circuits with the appropriate fluids and air-bleed the entire system. Check all connections for leaks and verify the system pressure. Set the heating controller in compliance with the documentation and manufacturer's recommendations. Check regularly proper function of all control and adjusting elements.

7 - Installing Insulation on the Tank

Instructions

Product description

Fleece thermal insulation with PU leather surface.

Warning

Insulation installation shall be done in two or three persons, depending on its size. The zippered fleece insulation **must not be installed at temperatures below 20°C**. If this cannot be avoided, the insulation shall be pre-warmed in another room to at least 20°C. It is impossible to install insulation of lower temperature, there is a risk of damage, esp. to the zipper.

Do not use any tools for installation.

Keep away from open fire.

How to install soft foam insulation with a PVC layer

1. Fix the tank following installation instructions.
2. Wrap the insulation around the tank carefully. Check that the insulation adheres to its body perfectly. This can be reached by rubbing and patting the insulation by hand from its center evenly in both directions until the insulation adheres to the tank's surface completely and no bubbles are left.
3. Use the holes for sleeves as a rest during the insulation installation.
4. At least one person presses the insulation to the tank, pulling both ends together. The other person closes the zipper.
5. Put on the upper insulation and cover.
6. Push on the covering plastic rosettes depending on the size of sleeves, or put on the flange plug(s) with insulation.
7. Finish the tank installation in compliance with the respective instructions and valid standards and rules.

Warranty on insulation

The insulation is covered by a 24-month warranty. This period starts the next day after the insulation is sold.

- Warranty shall become null and void if:
 - the procedure described in the Installation Manual was not respected,
 - the product was used for other purposes than intended.
- Warranty does not cover:
 - usual wear and tear,
 - damage caused by fire, water, electricity or a natural disaster,
 - defects caused by failure to use the product in compliance with its intended purpose, by improper use and insufficient maintenance,
 - defects caused by mechanical damage to the product,
 - defects caused by tampering or incompetent repair.



+ 20.0° C
+ 68.0° F

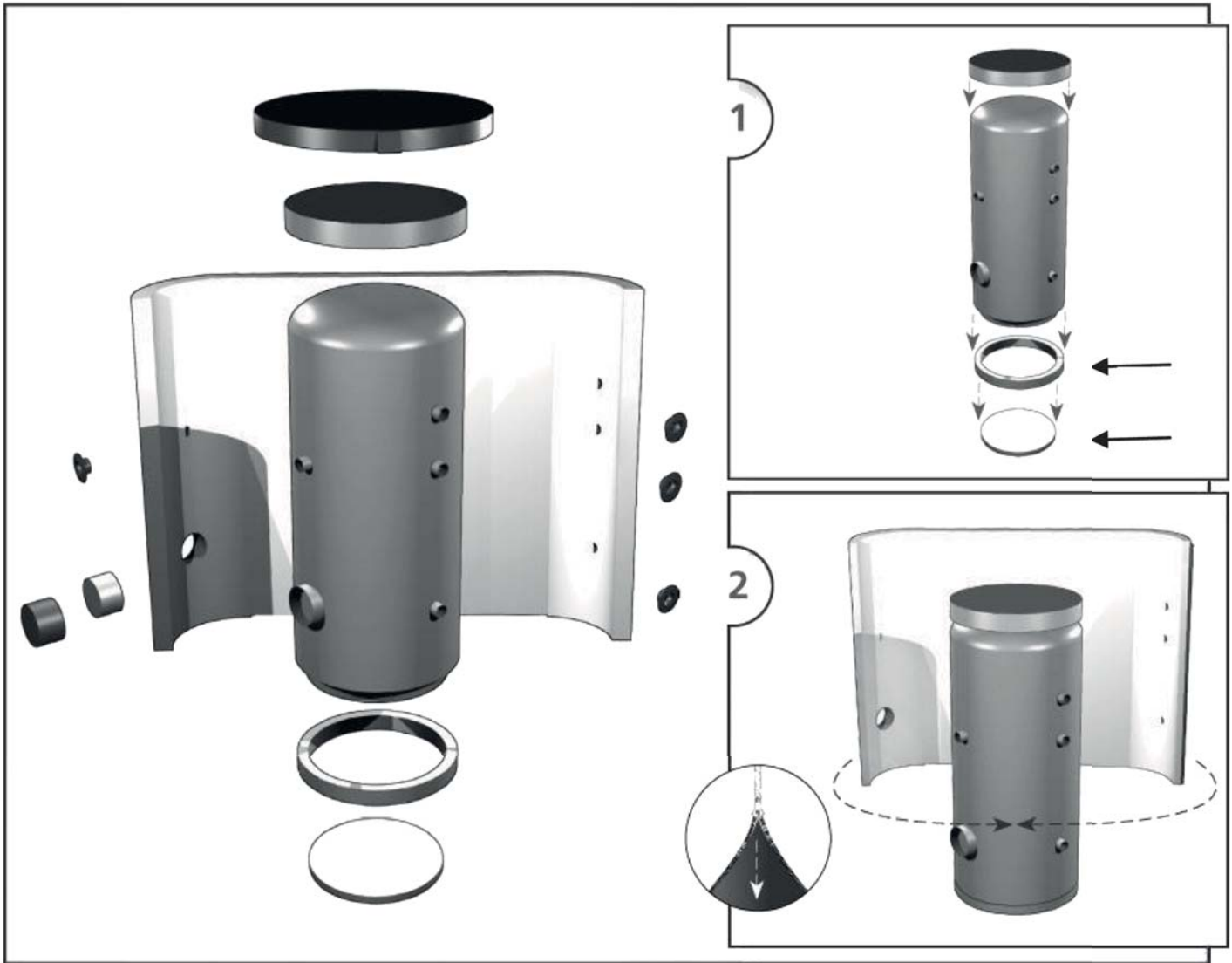

8 - Maintenance

If the tank is fitted with a heating element, disconnect it from the mains first. Clean the exterior of the tank with a soft cloth and a mild detergent. Never use abrasive cleaners or solvents.

Check all connections for leaks.

9 - Disposal

Packing shall be disposed of in compliance with the valid rules. When the product reaches the end of its life, it shall not be disposed of as household waste. It shall be dropped off at a Local Waste Recycling Center. Insulation shall be recycled as plastic and the steel vessel as scrap iron.

10 - Warranty

This product is covered by warranty under the conditions listed in this Manual and in compliance with the Warranty Certificate. A Warranty Certificate is an integral part of this accumulation tank scope of supply.

