



www.regulus.eu



LYRA 1000 DVS

Installation and Operation Manual
LYRA 1000 DVS THERMAL STORE

EN



LYRA 1000 DVS

CONTENTS

1	Description	3
1.1	Models	3
1.2	Tank protection	3
1.3	Thermal insulation	3
1.4	Packaging	3
2	General Information	3
3	Technical Data and Dimensions of Regulus LYRA 1000 DVS	4
4	Operation	4
5	Connection	5
5.1	Mounting pump stations and accessories onto	5
5.2	Connecting heating circuits	31
5.3	Connecting a DHW circuit	31
5.4	Connecting a solar circuit	31
5.5	Examples of heat source connection	32
5.6	Fitting electric heating elements	33
6	Installation and commissioning	34
6.1	Commissioning	34
7	Maintenance	34
8	Disposal	34
9	Warranty	34

1 Description

Regulus LYRA Thermal Stores are intended for accumulation and subsequent distribution of thermal energy from solid-fuel fired boilers, heat pumps, solar collectors, electric boilers etc. The Thermal Store shall be always connected to a sealed heating circuit. The tank comes with complete accessories for connection to heating circuits, solar system and hot water.

The accessories supplied represent a complete solution for connecting a heating system, connecting cold water inlet for DHW heating and subsequent DHW output. Heat sources shall be connected to the free inlets at the tank rear, following the diagrams included in this Manual (Chapter 5.5). When more heat sources are combined, some intelligent controller should be used to control the heat sources and sinks, incl. the Thermal Store charging and discharging, for example Regulus IR12 Intelligent Controller.

1.1 Models

There are 3 models of Regulus LYRA 1000 DVS:

- for 1 heating circuit, no DHW recirculation, no pool
- for 2 heating circuits, with DHW recirculation, with pool
- for 2 heating circuits, with DHW recirculation, no pool

1.2 Tank protection

The Thermal Store comes with no inner surface finish/anticorrosion protection, its outside is painted in grey.

1.3 Thermal insulation

Thermal insulation is included in the supply. It consists of 3 layers: the first one is soft insulation fitting tightly on the tank; the second, main layer, features thermal conductivity $\lambda=0.032$ W/m.K; the third layer is a hard, glossy washable surface. The total insulation thickness is 100 mm.

1.4 Packaging

Tanks are delivered standing, each screwed to its pallet, packed in bubble wrap. Included in the package are all components to be fitted on the tank. Insulation is packaged separately.

2 General Information

This Owners Manual is an integral and important part of the product and must be handed over to the User. Read carefully the instructions in this Manual as they contain important information concerning safety, installation, operation and maintenance. Keep this Manual for later reference. Installation shall be done by qualified staff only, in compliance with valid rules, standards and manufacturer's instructions.

This appliance is designed to accumulate heating water and distribute it subsequently. It shall be connected to a heating system and heat sources.

Using the Thermal Store for other purposes than above described (e.g. as a drinking water tank) is forbidden and the manufacturer accepts no responsibility for damage caused by improper or wrong use.

The output of heat sources not equipped with their own safety valve and connected to the tank fitted with the enclosed safety valve shall never exceed 110 kW.

3 Technical Data and Dimensions of Regulus LYRA 1000 DVS

codes: 13181, 13184, 13421

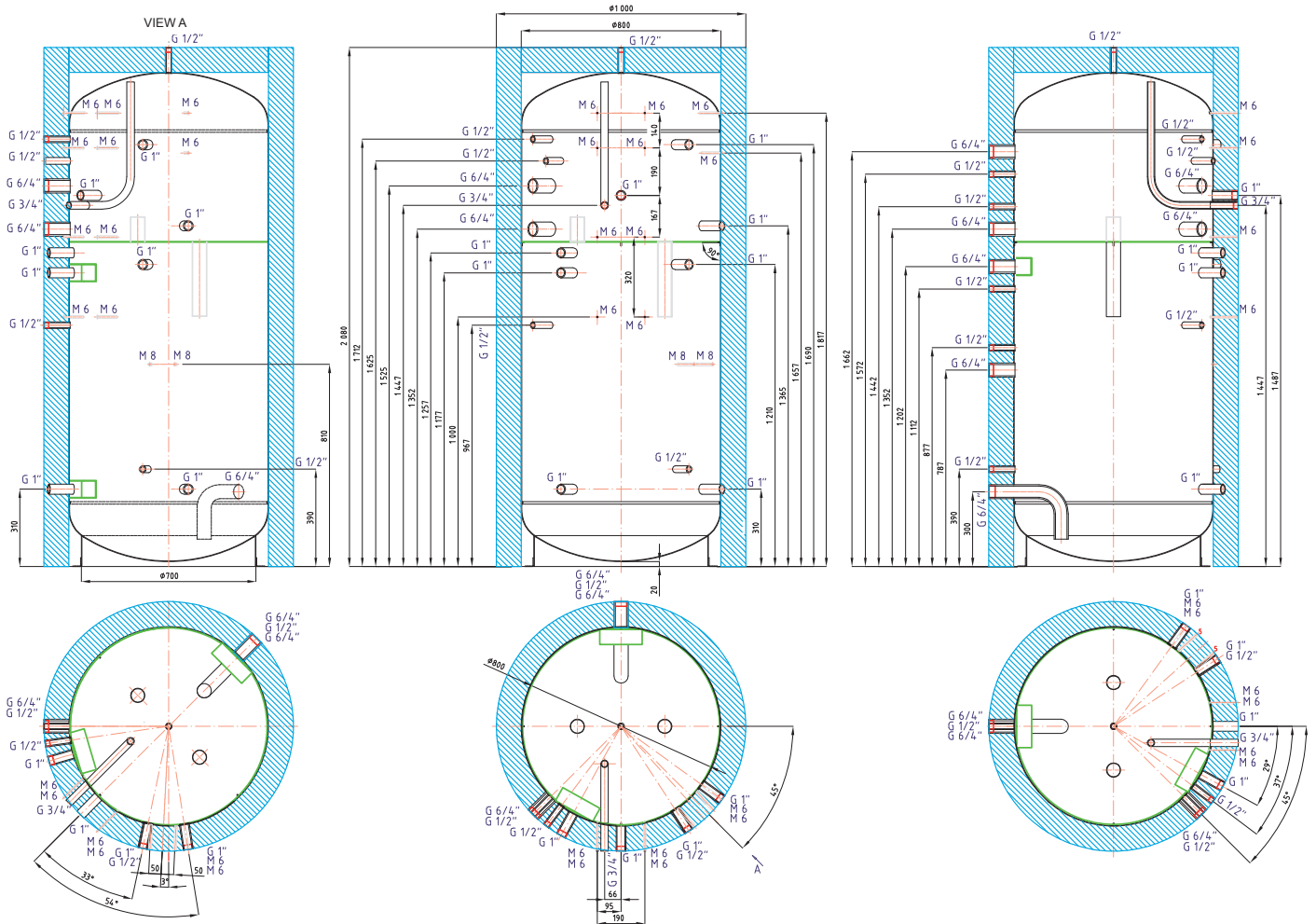

Total fluid volume in tank	925 l
Max. working temperature in tank	95 °C
Max. working pressure in tank	4 bar
Hot water recovery rate from 10 °C to 50 °C with 63 °C heating water temp.	1800 l/h (84kW)
Empty weight	125 kg
Tipping height without insulation	2120 mm

4 Operation

This Thermal Store is designed to heat water and accumulate heat for space heating in domestic or industrial applications, however always in sealed pressure circuits with forced circulation.

In the thermal store, heating water is heated up from several heat sources like various types of hot-water boilers, renewable energy sources (heat pumps, solar collectors), or electric heating elements.

5 Connection

5.1 Mounting pump stations and accessories onto

SCOPE OF SUPPLY

Regulus LYRA Thermal Store, code 13181 (the other thermal stores, codes 13184 and 13421, differ only in the number of heating circuits, or in the option to connect recirculation to the fresh water station, or in the pool heating option).

Regulus LYRA Thermal Store, code 13181 (the other thermal stores, codes 13184 and 13421, differ only in the number of heating circuits, or in the option to connect recirculation to the fresh water station, or in the pool heating option).

MODEL WITH NO POOL

13181 - LYRA 1000 DVS NO POOL		
Code	Item name	Qty
13171	PS1000 FWS DV Thermal Store for LYRA DV	1 pcs
13172	Insulation for PS1000 FWS DV Thermal Store code 13171, NEODUL	1 pcs
12224	Pump station for Thermal Store – 2 circuits	1 pcs
14866	S2 Solar 3 Pump station, ST25/6	1 pcs
9717	Fresh water station, with recirculation, FWC3 controller	1 pcs
12226	Assy Connection Kit for LYRA	1 pcs
12687	TSV3 Assy for LYRA	1 pcs
13983	T-Piece Assy for LYRA	1 pcs
12689	Pressure Gauge Assy for LYRA	1 pcs
12690	Angled Ball Valve Assy for LYRA	1 pcs
13236	Ball Valve & Elbow Assy for LYRA	1 pcs
13234	Connection Kit for TSV Assy, for LYRA	1 pcs
13237	Accessory Kit for LYRA and VEGA	1 pcs
12222	2-Circuit Pump Station Cover, for 1000l thermal store	1 pcs
12223	Front Insulation for 2-Circuit Pump Station Cover	1 pcs
12720	Top Insulation for 2-Circuit Pump Station Cover, 1000 l	1 pcs
12713	Black Knurled Screw, M6x1-10 PA 6.6	4 pcs
13263	1" M Ball Valve Assy for tanks with DV	1 pcs
13264	Zone Valve Assy for DV inlet	1 pcs
13265	1"M Ball Valve Assy for lower return	1 pcs
13266	Connection Assy - circulation pump	1 pcs
13267	Connection Assy - zone valve to DV	1 pcs
13268	Zone Valve Assy for DV outlet	1 pcs
13275	DV Plate HE Solar Inlet Assy	1 pcs
13270	1"M Ball Valve Assy for upper return	1 pcs
13451	Solar Pump Station Connection Kit for Tanks with DV 193	1 pcs
12128	Yonos Para 25/1-6 RKC Pump, 180mm, 6/4"	1 pcs
9551	DV193-60E Stainless Steel Plate Heat Exchanger, insulated	1 pcs
13437	Expansion Vessel Connection Kit for Lyra/Vega	1 pcs
13452	DV193 Fixing Kit for Lyra/Vega	1 pcs
12226 - ASSY CONNECTION KIT		
Code	Item name	Qty
11271	DN25 Pipe for water, 250-500 mm long, 1" F and M threads	1 pcs
13984	DN25 Pipe for water, 5/4" nut, 580 mm long	1 pcs
3016	DN25 Pipe for water, 200-400 mm long, 1" FM	1 pcs
3041	DN20 Pipe for water, 250-500 mm long, 3/4" F and M threads	2 pcs
8306	3/4" M/F Elbow, brass	1 pcs
6447	Insulation DNa 28, 13 mm thick, 2m	1,2 m
7187	Insulation DNa 35, 13 mm thick, 2m	1,5 m
12996	M 6x16 Stainless Steel Bolt (Allen head), DIN 912/A2	8 pcs
7853	Washer 6.5 (large diam. 3d)	8 pcs
9980	1" PTFE Nut Gasket - 18.5x30x2 mm	3 pcs
9978	3/4" PTFE Nut Gasket - 15x24 mm	3 pcs
7691	Brass hex plug, 1" M	1 pcs

13234 - CONNECTION KIT FOR TSV ASSY		
Code	Item name	Qty
11946	DN20 Pipe for water, 65-125 mm long, 3/4" F and M threads	1 pcs
998	Ball Valve 3/4" M/F, red butterfly handle	1 pcs
6970	3/4" M/M brass hex nipple	1 pcs
13237 - ACCESSORY KIT		
Code	Item name	Qty
10474	Thermometer, d=63 mm, sheath l=150, G1/2", rear conn., 0-120 °C	2 pcs
605	3 bar Safety Valve, G 1/2" F/F	1 pcs
6971	1/2" M/M Brass Hex Nipple, thick wall	2 pcs
11965	1/2" Ball Valve, F/F	1 pcs
11708	1/2" Automatic Air Vent Valve	1 pcs
13437 - EXPANSION VESSEL CONNECTION KIT		
Code	Item name	Qty
11969	6/4" Ball Valve, F/F	1 pcs
7627	Hex Nipple, 6/4", M/M, thick wall	2 pcs
8757	6/4" T-piece FFF, brass	1 pcs
8766	Reducing Hex Nipple, 1" x 6/4", M/M	1 pcs
7049	1" T-piece FFF, brass	1 pcs
6969	1" M/M brass hex nipple, thick wall	1 pcs
7701	Reducing Hex Nipple, 1" x 1/2", M/F, brass	1 pcs
11713	1/2" drain valve, no handle, with cap	1 pcs
13451 - SOLAR PUMP STATION CONNECTION KIT		
Code	Item name	Qty
7223	SOLAR PUMP STATION CONNECTION KIT	1 pcs
13447	DN 20 pipe (1" nut), l=1000 mm	1 pcs
13448	DN 20 pipe (1" nut), l=460 mm	1 pcs
3041	DN20 pipe for water, 250-500 mm long, 3/4" F/M	1 pcs
13449	DN 20 pipe (1" nut), l=360 mm	1 pcs
13450	DN 20 pipe (1" nut), l=330 mm	1 pcs
3012	DN20 pipe for water, 100-200 mm long, 3/4" F/M	1 pcs
12996	M 6x16 Stainless Steel Bolt (Allen head), DIN 912/A2	2 pcs
7853	Washer 6.5 (large diam. 3d)	2 pcs
9980	1" PTFE Nut Gasket - 18.5x30x2 mm	8 pcs
6447	Insulation DNa 28, 13 mm thick, 2m	4 m
13452 - DV 193 FIXING KIT		
Code	Item name	Qty
10192	3/4" FF Brass Elbow	1 pcs
8307	3/4" Radiator Straight Fitting	1 pcs
13438	DV193-60 Support for Thermal Store	1 pcs
7259	M 8x18 Stainless Steel Bolt (Allen head), DIN 912/A2	2 pcs
7008	Washer 8.4 (large diam. 3d), stainless steel, DIN 9021/A2	4 pcs

MODELS FOR A POOL

13421 - LYRA 1000 DVS FOR A POOL		
Code	Item name	Qty
13171	PS1000 FWS DV Thermal Store for LYRA DV	1 pcs
13172	Insulation for PS1000 FWS DV Thermal Store code 13171, NEODUL	1 pcs
12224	Pump station for Thermal Store – 2 circuits	1 pcs
14866	S2 Solar 3 Pump station, ST25/6	1 pcs
9717	Fresh water station, with recirculation, FWC3 controller	1 pcs
12226	Assy Connection Kit for LYRA	1 pcs
12687	TSV3 Assy for LYRA	1 pcs
12689	Pressure Gauge Assy for LYRA	1 pcs
12690	Angled Ball Valve Assy for LYRA	1 pcs
13236	Ball Valve & Elbow Assy for LYRA	1 pcs
13983	T-Piece Assy for LYRA	1 pcs
13234	Connection Kit for TSV Assy, for LYRA	1 pcs
13237	Accessory Kit for LYRA and VEGA	1 pcs
12222	2-Circuit Pump Station Cover, for 1000l thermal store	1 pcs
12223	IFront Insulation for 2-Circuit Pump Station Cover	1 pcs
12720	Top Insulation for 2-Circuit Pump Station Cover, 1000 l	1 pcs
12713	Black Knurled Screw, M6x1-10 PA 6.6	4 pcs
13263	1" M Ball Valve Assy for tanks with DV	1 pcs
13264	Zone Valve Assy for DV inlet	1 pcs
13265	1"M Ball Valve Assy for lower return	1 pcs
13266	Connection Assy - circulation pump	1 pcs
13267	Connection Assy - zone valve to DV	1 pcs
13268	Zone Valve Assy for DV outlet	1 pcs
13269	Solar Pool and DV Inlet Assy	1 pcs
13270	1"M Ball Valve Assy for upper return	1 pcs
13272	Pool Zone Valve Assy for tanks with DV	1 pcs
13951	Solar Pump Station Connection Kit for pool models with DV193	1 pcs
12128	Yonos Para 25/1-6 RKC Pump, 180mm, 6/4"	1 pcs
9551	DV193-60E Stainless Steel Plate Heat Exchanger, insulated	1 pcs
13437	Expansion Vessel Connection Kit for Lyra/Vega	1 pcs
13452	DV193 Fixing Kit for Lyra/Vega	1 pcs
13951-SOLAR PUMP STATION CONNECTION KIT FOR POOL MODELS		
Code	Item name	Qty
7223	Reducing Hex Nipple, 1" x 3/4", M/F, brass	1 pcs
13952	DN 20 pipe (1" nut), l=1000 mm	1 pcs
13448	DN 20 pipe (1" nut), l=460 mm	1 pcs
3041	DN20 pipe for water, 250-500 mm long, 3/4" F/M	1 pcs
13449	DN 20 pipe (1" nut), l=360 mm	1 pcs
13450	DN 20 pipe (1" nut), l=330 mm	1 pcs
3012	DN20 pipe for water, 100-200 mm long, 3/4" F/M	1 pcs
12996	M 6x16 Stainless Steel Bolt (Allen head), DIN 912/A2	2 pcs
7853	Washer 6.5 (large diam. 3d)	2 pcs
9980	1" PTFE Nut Gasket - 18.5x30x2 mm	8 pcs
6447	Insulation DNa 28, 13 mm thick, 2m	4 m

The models for a pool involve more Kits identical with the model with no pool. The identical Kits for both models can be found under the following codes: 12226, 13234, 13237, 13437, 13452.

MOUNTING INSTRUCTIONS

WARNING! At least 20°C and 4 persons are necessary to mount the insulation. All threaded connections shall be sealed either with a thread sealant or with the gaskets included in separate kits.

1. Remove the tank from its pallet and place it to its approximate position, shift the bottom insulation under the tank.



2. Slide the insulation inserts into the openings for connections.

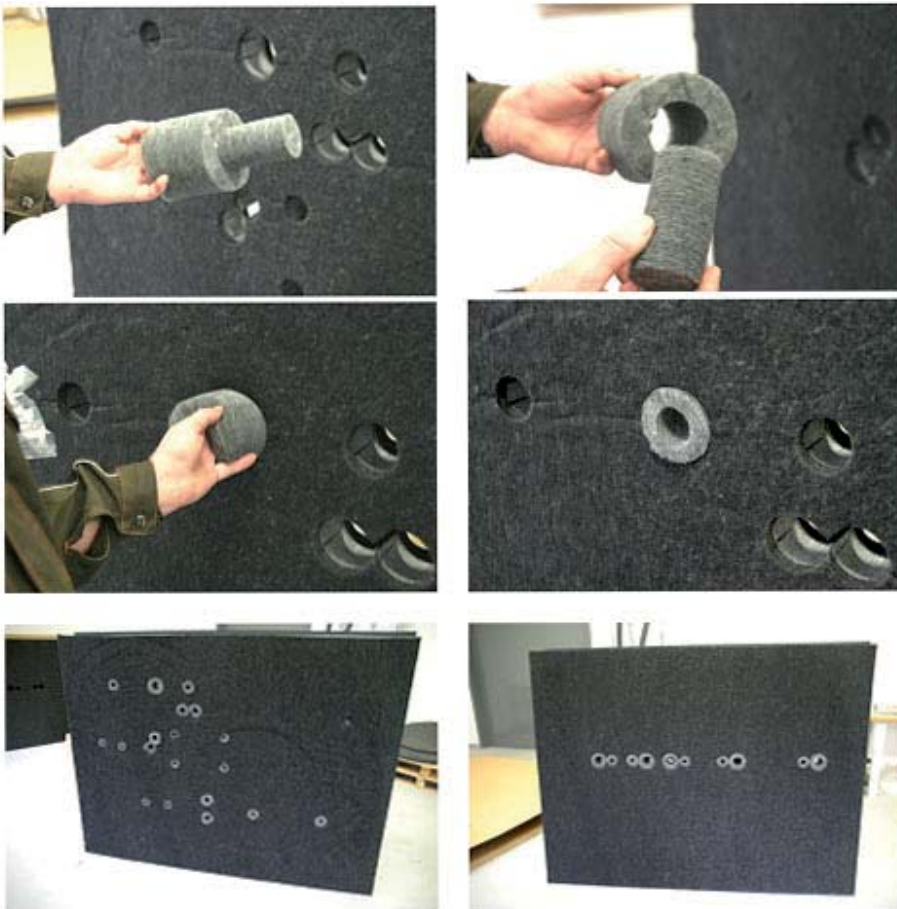

3. Fit on the front insulation and subsequently the rear insulation. Check their proper position against the sleeves prior to final fixing. Use the jig to close the locks.



4. Peel off the protective foil from the insulation, apply the self-adhesive annuluses around the openings for connections. Some annuluses are cut out, these shall be used in places where openings are close to each other (the annuluses overlap).



5. Fit the Angled Ball Valve Assy (code 12690). From this point on, it is important to stick to the sequence of installation steps described below!



6. Fit the Pressure Gauge Assy (code 12689).



7. Fit the plug (code 7691) into the 1" sleeve below the Pressure Gauge Assy.

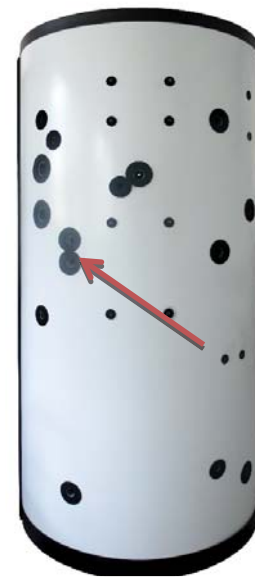

8. Fit the 3/4" brass hex nipple (code 6970) into the sleeve, and the ball valve (code 998, included in Kit 13234) onto the nipple. Turn the ball valve into a position shown in the Fig.

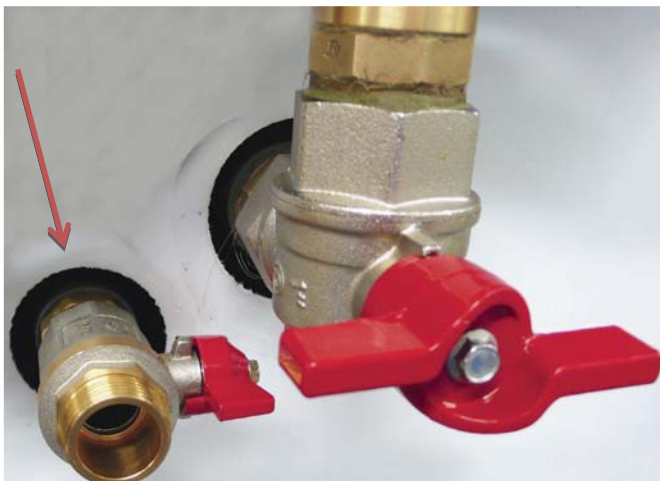

9. Fit the Ball Valve & Elbow Assy (code 13236) into the lower 1" sleeve.



10. Fit the metal sheet against the four pins and fix it using 4 screws M6x16 with washers (codes 12996 and 7853, included in Kit 12226). Also place insulation washers under and on the metal sheet and loosen the clamps. Fit the Pump Station with 4-way mixing valves (code 12224 or 12225). Join it with the earlier fitted Angled Ball Valve Assy using a 5/4" union nut (see Point 5). Tighten the clamps.

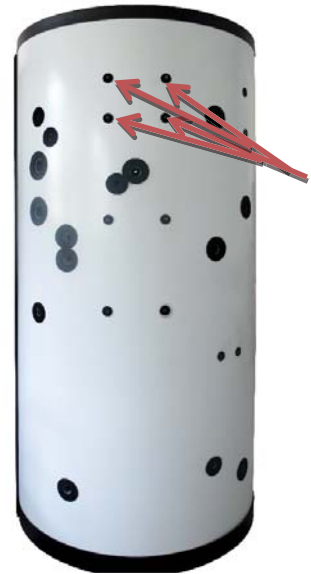

11. Fit the Fresh Water Station (code 9717 or 9913) using 4 screws M6x16 with washers (codes 12996 and 7853, included in Kit 12226). Then fit the 3/4" elbow (code 8306, included in Kit 12226) to the Fresh Water Station outlet.



12. Using the 3/4" pipe 100 mm long (code 11946, included in Kit 13234), connect the TSV3 Assy (code 12687) with the 3/4" ball valve (see Point 8). Prior to assembly, cut the insulation and slide it onto the pipe.

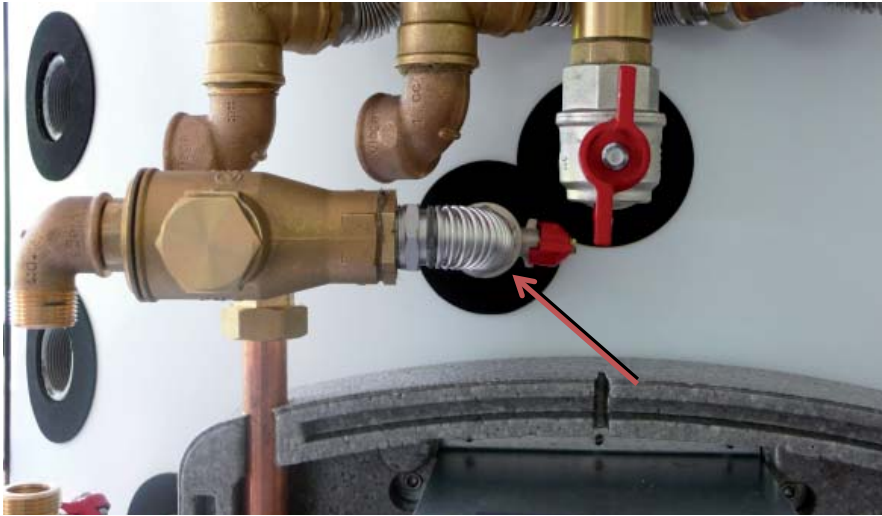

13. Connect the TSV3 Assy with the Fresh Water Station.



14. Stretch the pipes to their preliminary lengths, cut the insulation and slide it onto the pipes (included in Kit 12226):
- 1 pipe 1" to 410 mm (code 11271), insulation circa 500 mm long
 - 1 pipe 1" to 250 mm (code 3016), insulation circa 300 mm long
 - 1 pipe 3/4" to 450 mm (code 3041), insulation circa 550 mm long
 - 1 pipe 3/4" to 320 mm (code 3041), insulation circa 400 mm long
 - 1 pipe 5/4" DN 25 to 580 mm (code 13984), insulation circa 700 mm long.

15. Using the 1" pipe, 250 mm long (code 3016), connect the Manometer Assy with the inner elbow of the pump station with 4-way valves.



16. Fit the 1" pipe, 410 mm long (code 11271) to the pump station.



17. Fit the 3/4" pipes 320 and 450 mm long (code 3014) to the T-Piece Assy (code 13983). The 450 mm long pipe shall be fitted to the right, see Fig.

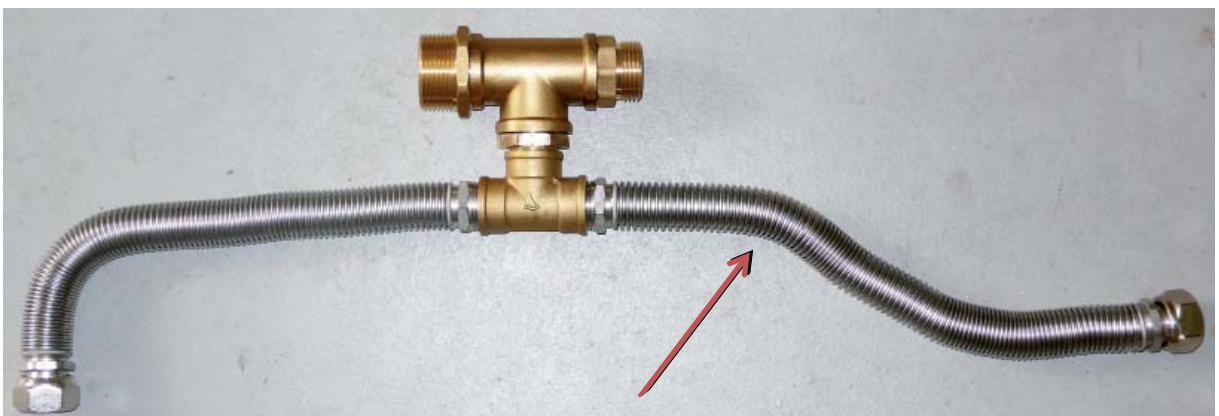

18. Connect the T-Piece Assy at 3 points, see Fig.

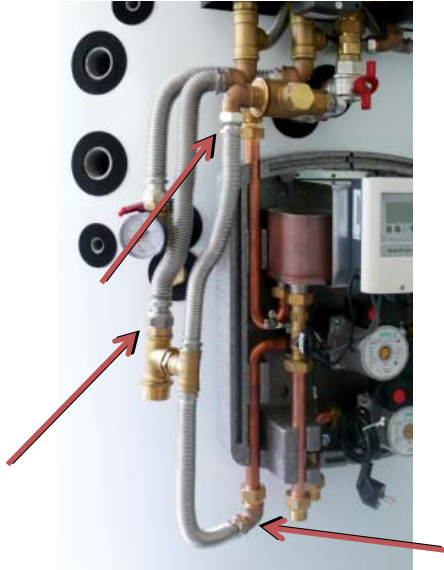

19. Using the 5/4" pipe, 580 mm long (code 13984), connect the T-Piece Assy with the Ball Valve Assy.



20. Fit two thermometers (code 10474, included in Kit 13237), 6/4" and 1/2" plugs or electric heating elements and a safety thermostat.

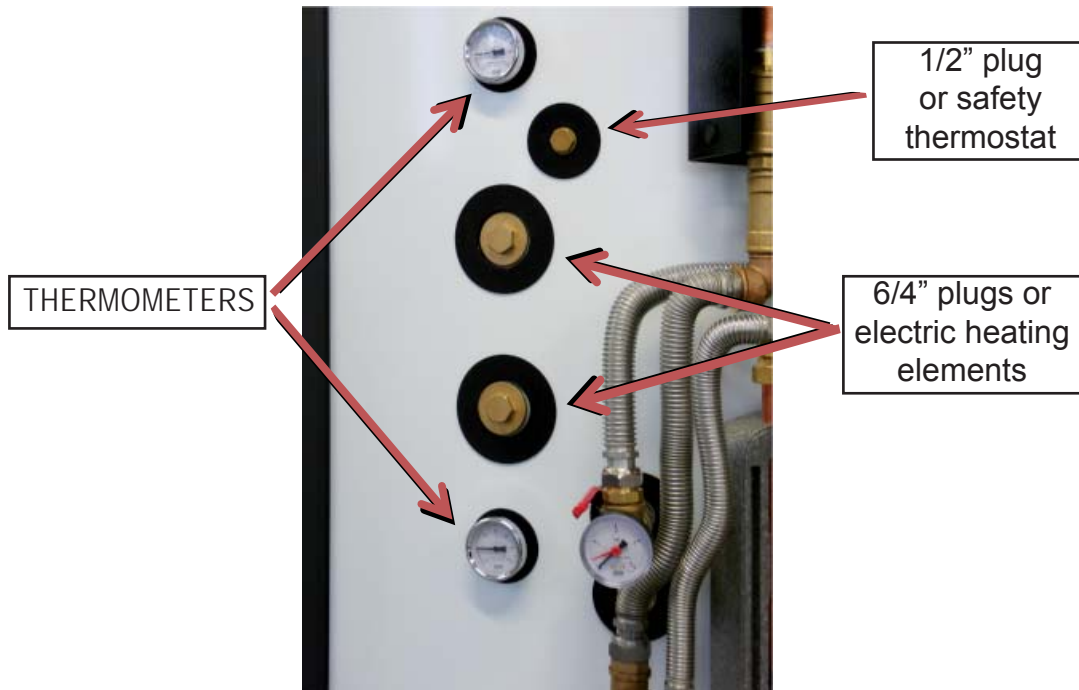

21. Stretch the pipes to their preliminary lengths, cut the insulation and slide it onto the pipes:

Model for a pool (included in Kit 13951):

- 1 pipe 1" DN20, 1000 mm (code 13952), insulation circa 1100 mm long
- 1 pipe 1" DN20, 460 mm (code 13448), insulation circa 1100 mm long
- 1 pipe 3/4" to 500 mm (code 3041), insulation circa 600 mm long
- 1 pipe 1" DN20, 360 mm (code 13449), insulation circa 450 mm long
- 1 pipe 1" DN20, 330 mm (code 13450), insulation circa 400 mm long
- 1 pipe 3/4" to 200 mm (code 3012), insulation circa 250 mm long

Model without a pool (included in Kit 13451):

- 1 pipe 1" DN20, 1250 mm (code 13447), insulation circa 1350 mm long
- 1 pipe 1" DN20, 460 mm (code 13448), insulation circa 550 mm long
- 1 pipe 3/4" to 500 mm (code 3041), insulation circa 600 mm long
- 1 pipe 1" DN20, 360 mm (code 13449), insulation circa 450 mm long
- 1 pipe 1" DN20, 330 mm (code 13450), insulation circa 400 mm long
- 1 pipe 3/4" to 200 mm (code 3012), insulation circa 250 mm long.

22. Fit the Ball Valve Assy for upper return (code 13270).



23. Fit the 1" M to 3/4" F reducing piece (code 7223, included in Kit 13451 or 13951) onto the solar pump station (code 14866) below the pump.

Model for a pool: Fit the Pool Inlet Assy (code 13269) as shown in the figure.

Model with no pool: Fit the Plate HE Inlet Assy (code 13275) as shown in the figure.

POOL VERSION



NO POOL VERSION



24. Fit the solar pump station (code 14866) using 2 M6x16 bolts with washers (codes 12996 and 7853, included in Kit 13451 or 13951).

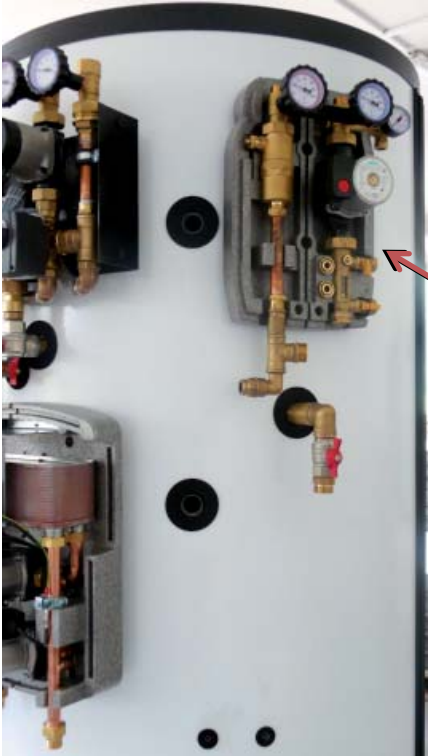

25. Fit the Ball Valve Assy for tanks with a plate HE (code 13263).



26. Fit the plate heat exchanger support (code 13438, included in Kit 13452) using 2 bolts M8x18 with washers (codes 7259 and 7008), put washers under the support and then also onto the support.



- 27 Fit the hex nipple (code 6971) into the sleeve first, and then the safety valve (code 605, included in Kit 13237).

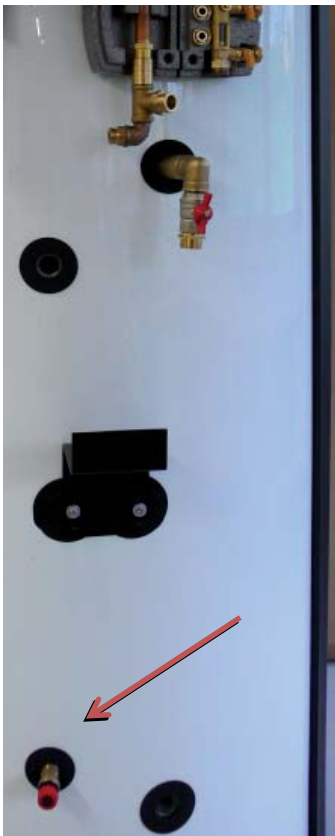

28. Fit the Ball Valve Assy for lower return (code 13265).

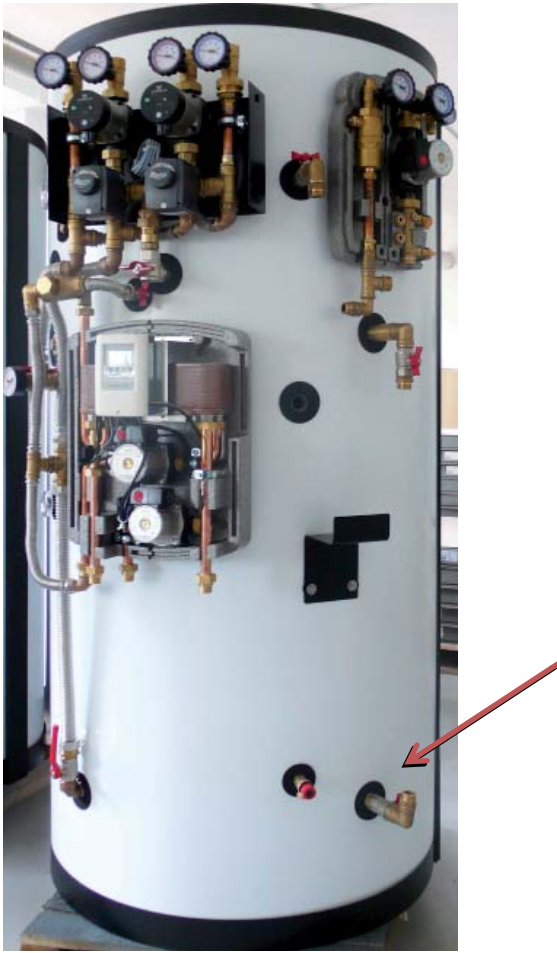

29. Fit the Zone Valve Assy for DV outlet (code 13268).

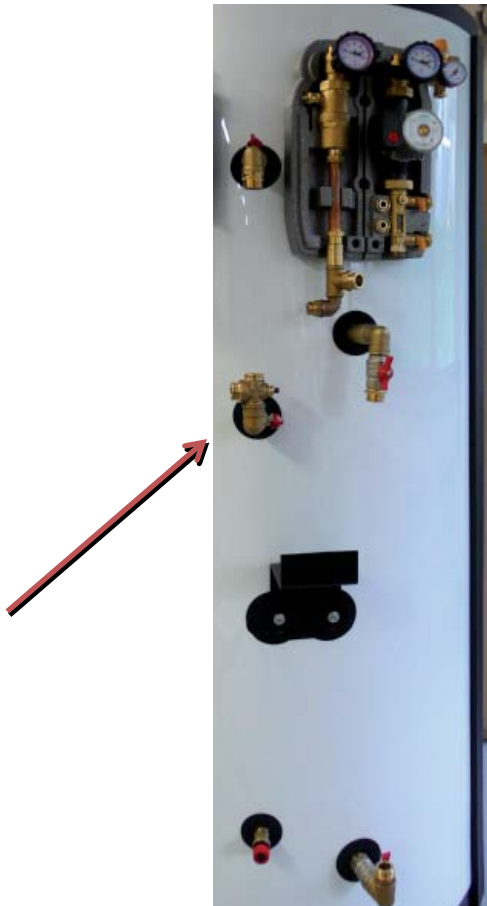

30. Fit the Connection Assy - zone valve to DV (code 13267).



31. **Model for a pool:** Remove the last part of the radiator fitting from the Zone Valve Assy (code 13272) and screw it to the plate heat exchanger as shown below.
Model with no pool: Screw the fitting (code 8307) to the plate heat exchanger (code 9551) as shown below.



32. Fit the 3/4" FF elbow (code 10192, included in Kit 13452) to the plate heat exchanger.

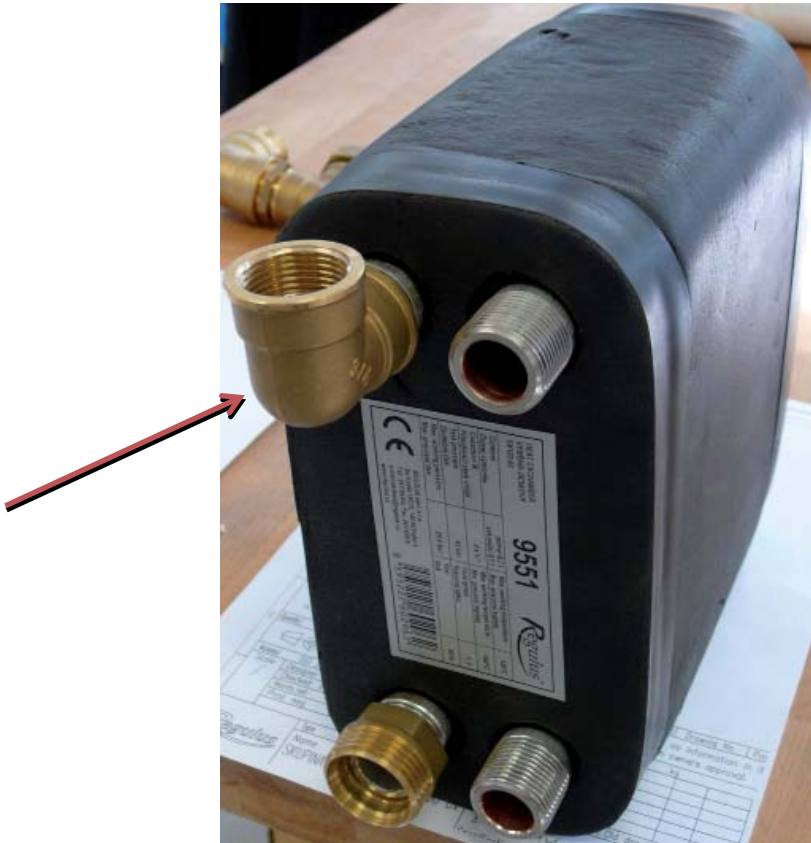

33. Fit the Assy for circulation pump connection (code 13266) to the plate heat exchanger.



34. **This point applies to models with pool only:**
Fit the rest of the Pool Zone Valve Assy (code 13272).

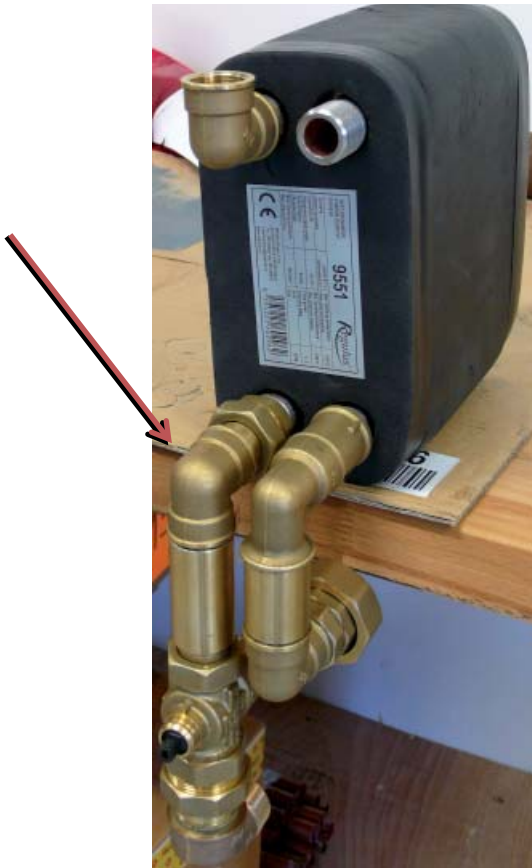

35. **Model for a pool:** Using the 1" pipe 1000 mm long (code 13952), connect the solar pump station reducing piece with the AB port of the zone valve, see fig.

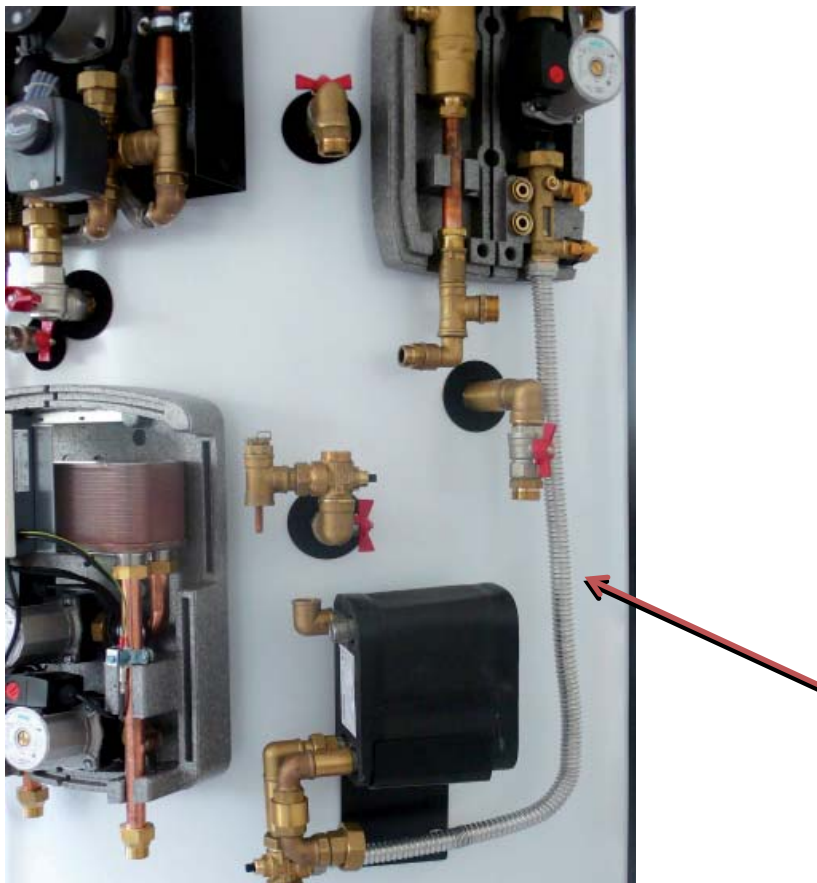

Model with no pool: Using the 1" pipe 1250 mm long (code 13447), connect the solar pump station reducing piece with the plate heat exchanger, see fig.



36. Using the 3/4" pipe 500 mm long (code 3041), connect the plate heat exchanger elbow with the solar pump station, see fig.



37. Using the 3/4" pipe 200 mm long (code 3012), connect the plate heat exchanger to the Assy for connecting a zone valve.

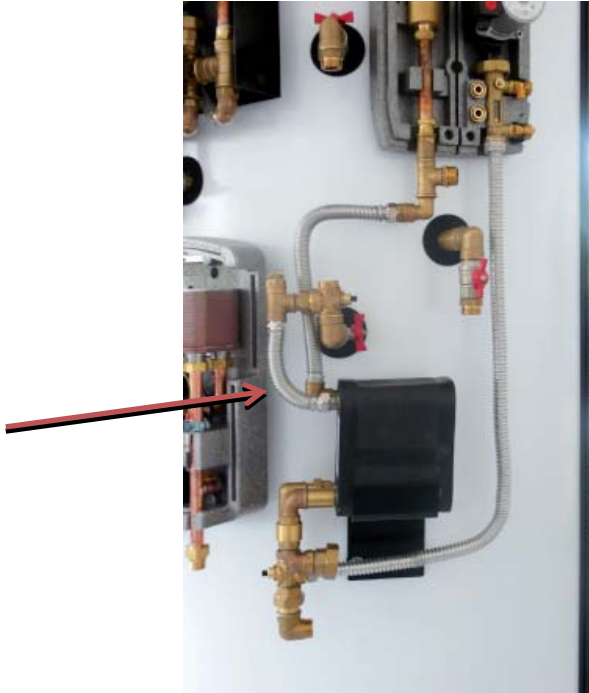

38. Fit the pump (code 12128) to the Assy for connecting a circulation pump. The flow direction is into the heat exchanger (the arrow pointing left).



39. Fit the Zone Valve Assy (code 13264) to the pump.
The port B of the zone valve shall be oriented upwards!



40. Using the 1" pipe 460 mm long (code 13448), connect the zone valve with the ball valve.



41. Using the 1" pipe 360 mm long (code 13449), connect the zone valve with the ball valve.



42. Using the 1" pipe 330 mm long (code 13450), connect the zone valve with the ball valve. Fit the actuators onto the zone valves.



43. Push the front and top insulation onto the pump station with 4-way valves (codes 12223 and 12720).

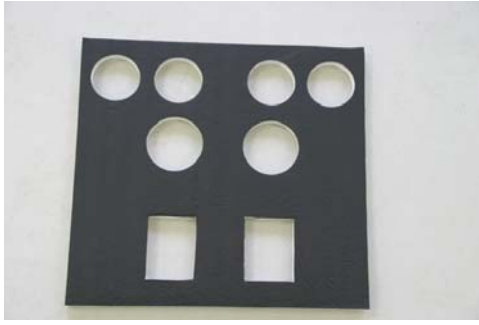

44. Connect the terminals of the pumps, push the cables behind the insulation.



45. Fit the plastic cover onto the pump station with 4-way valves and fix it with 4 plastic screws M6x10 (code 12713).



46. Put the top insulation and plastic cover onto the tank.

47. Fit the automatic air release valve (code 11708) with the ball valve (code 11965) and fitting (code 6971, all included in Kit code 13237).



Completely fitted tank:



5.2 Connecting heating circuits



1. Return line from Heating Circuit 1 – G1”F
2. Flow to Heating Circuit 1 – G1”F
3. Flow to Heating Circuit 2 – G1”F
4. Return line from Heating Circuit 2 – G1”F

5.3 Connecting a DHW circuit

1. Domestic hot water outlet - G3/4”M
2. DHW recirculation inlet - G3/4”M
3. Cold water inlet - G 3/4”M



5.4 Connecting a solar circuit



1. Inlet from solar collectors – G3/4” M
2. Return line to solar collectors – G3/4” M

5.5 Examples of heat source connection

Inlets and outlets for connecting heat sources are located opposite the heating pump station.

EXAMPLE I:

Fireplace insert with hydronic heat exchanger and a hydronic heating boiler (electric-, gas-, oil- or pellet-fired).

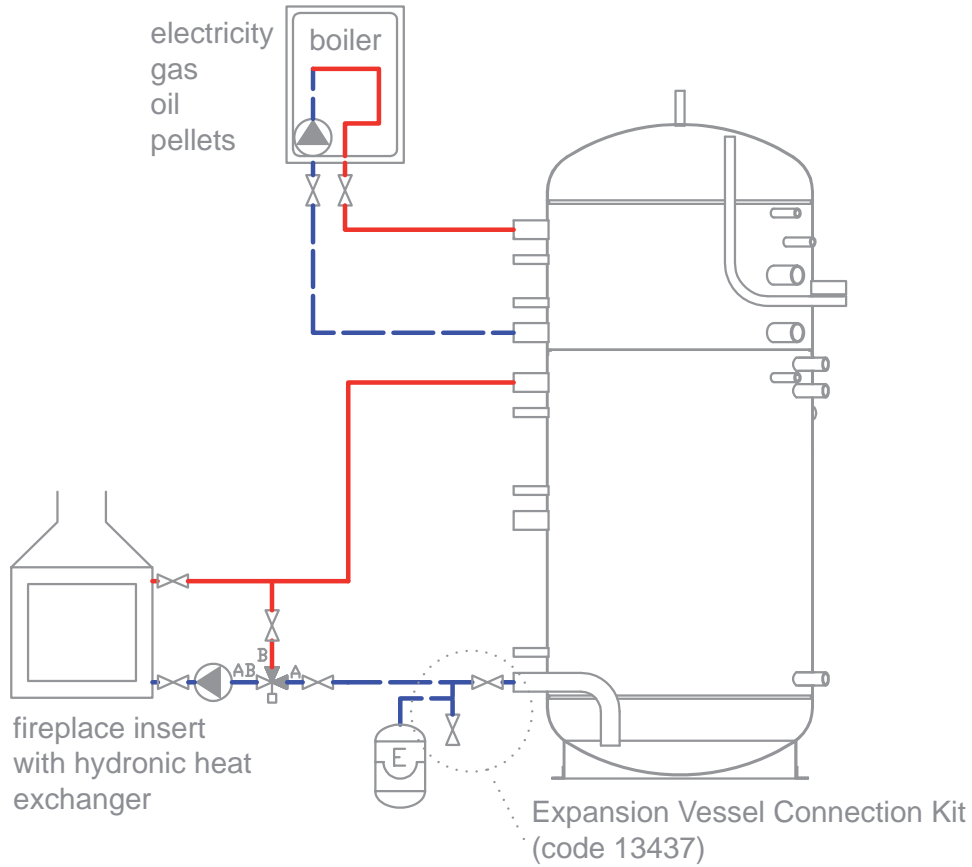

EXAMPLE II.

Fireplace insert with a hydronic heat exchanger, heat pump with max. flow temperature up to 55°C, electric heating elements.

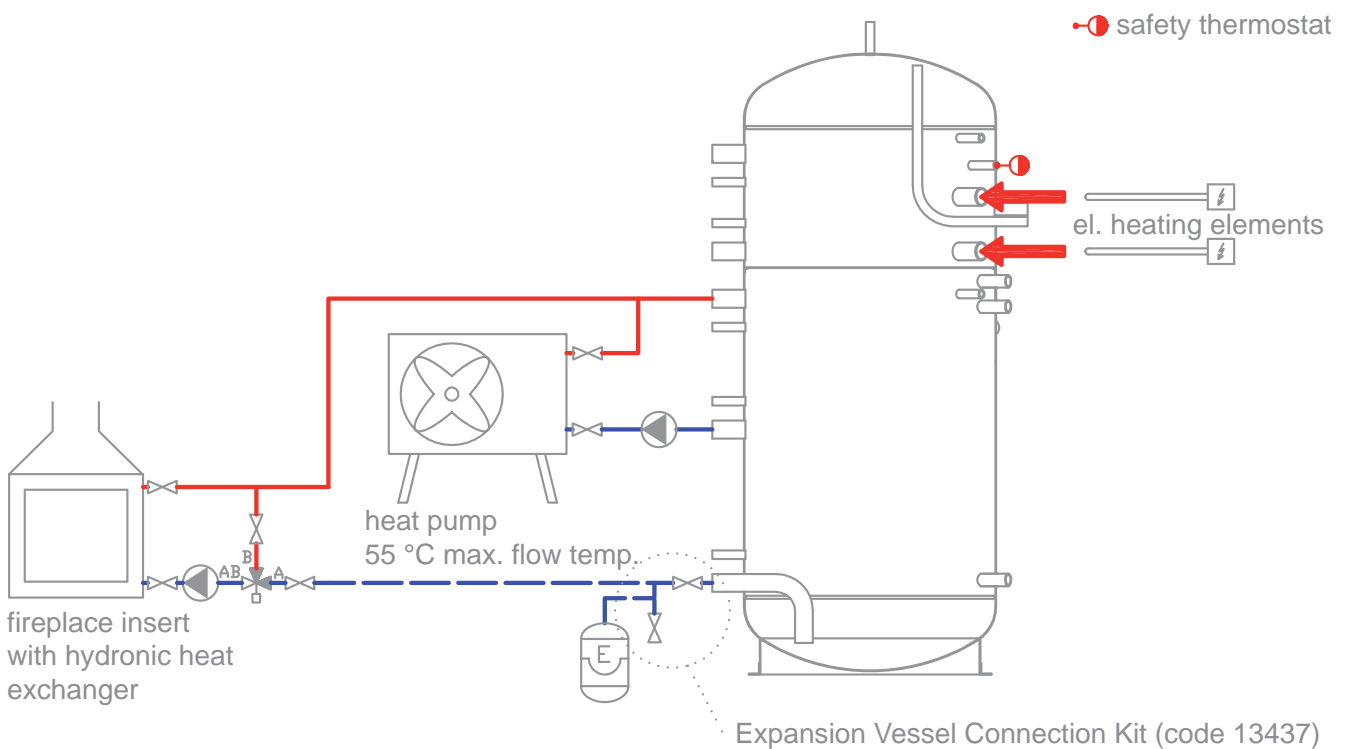

EXAMPLE III.

Heat pump with max. flow temperature over 60°C, el. heating elements

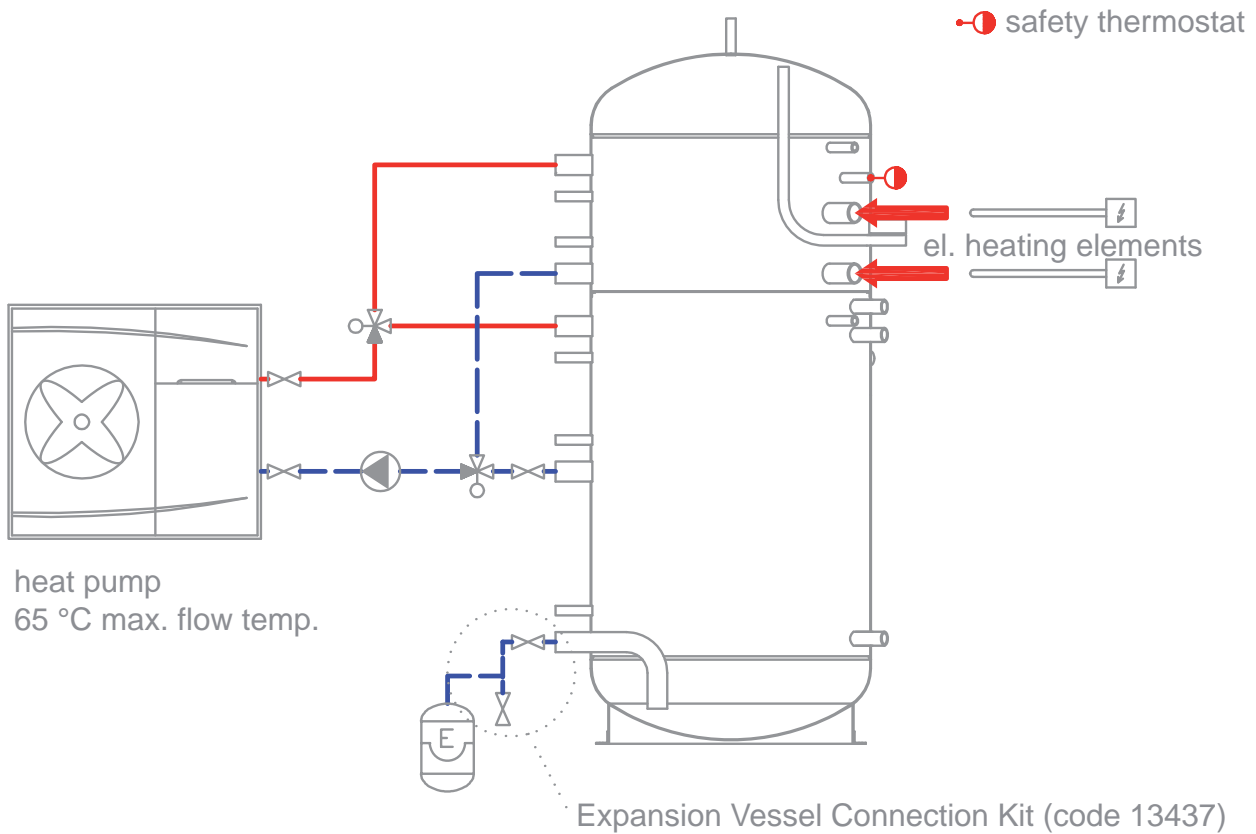

5.6. Fitting electric heating elements

The Thermal Store can be fitted with up to 2 electric heating elements of max. 12 kW total power output. The G6/4" sleeves, located in the middle of the tank below the heating pump station, are intended for these elements. The G1/2" sleeve below the upper thermometer is designed to receive a safety thermostat. All el. heating elements shall be installed together with a safety temperature limiter.

El. heating elements shall be wired by qualified staff only.

6 - Installation and Commissioning

Installation shall meet valid rules and may be done by qualified staff only. EI. heating elements shall be wired by qualified staff only.

Defects caused by improper installation, use or handling are not covered by warranty.

After the tank is installed and connected to an existing heating system, it is recommended to clean the entire heating system using a suitable cleaning agent, e.g. MR-501/R.

Anti-corrosion protective liquid should be also used, e.g. MR-501/F.

6.1 - Commissioning

The tank shall be filled up together with the heating system, respecting valid standards and rules. In order to minimize corrosion, special additives for heating systems should be used. The quality of heating water depends on the quality of filling water at commissioning, on the top-up water and on the frequency of topping up. This has a strong influence on the lifetime of heating systems. Poor quality of heating water may cause problems like corrosion or incrustation, esp. on heat transfer surfaces.

Fill the heating circuits with the appropriate fluids and air-bleed the entire system. Check all connections for leaks and verify the system pressure. Set the heating controller in compliance with the documentation and manufacturer's recommendations. Check regularly proper function of all control and adjusting elements.

7 - Maintenance

If the tank is fitted with a heating element, disconnect it from the mains first. Clean the exterior of the tank with a soft cloth and a mild detergent. Never use abrasive cleaners or solvents.

Check all connections for leaks.

8 - Disposal

Packaging shall be disposed of in compliance with the valid rules. When the product reaches the end of its life, it shall not be disposed of as household waste. It shall be dropped off at a Local Waste Recycling Center. Insulation shall be recycled as plastic and the steel vessel as scrap iron.

9 - Warranty

This product is covered by warranty under the conditions listed in this Manual and in compliance with the Warranty Certificate. A Warranty Certificate is an integral part of this Thermal Store scope of supply.

