

DATA SHEET

CSE2 MIX F G75 1F Pump Station



Main Features

Application	It provides flow through the heating system, mixes to the outlet temperature in an electric actuated mixing valve (controlled by an external controller). The pump station includes a filter with magnet, so it is also suitable for older steel pipe systems. It can be easily mounted on a wall or on a manifold for multiple heating circuits.
Description	Consists of Grundfos UPM3 FLEX AS 25-75 pump, LK 840 3-way mixing valve with AVC actuator, filter w. magnet, check valve, ball valves w. sensor sheaths, insulation.
Working fluid	Water, antifreeze heat-transfer fluid for heating systems.
Installation	Vertically on a wall or manifold (125 mm pitch).
Code	17484

Pump Station Data

Fluid working temperature	5–95 °C
Max. working pressure	10 bar
Min. working pressure	0.5 bar
Ambient temperature	5–40 °C
Max. relative humidity	80 %, non condensing
Pump station max. power input	60 W
Pump power supply	230 V, 50 Hz
Min./max. current to pump	0.04/0.58 A
Mixing valve actuator torque	5 Nm
Angle of the mixing valve actuator	90°
Mixing valve shift time	120 s
Power supply and control of the mixing valve actuator	230 V, 50 Hz; from external controller w. 3-point control
Mixing valve Kvs	6.3 m ³ /h
Max. pressure difference	5 mH ₂ O (at mixing valve inlets)
Leak rate	< 1 % Kvs at 5 mH ₂ O pressure difference (at mixing valve inlets)
Insulation material	EPP RG 60 g/l
Overall dimensions	360 x 181 x 245 mm
Total weight	6.7 kg
Connections	4 x G 1" F

Pump Performance Curves

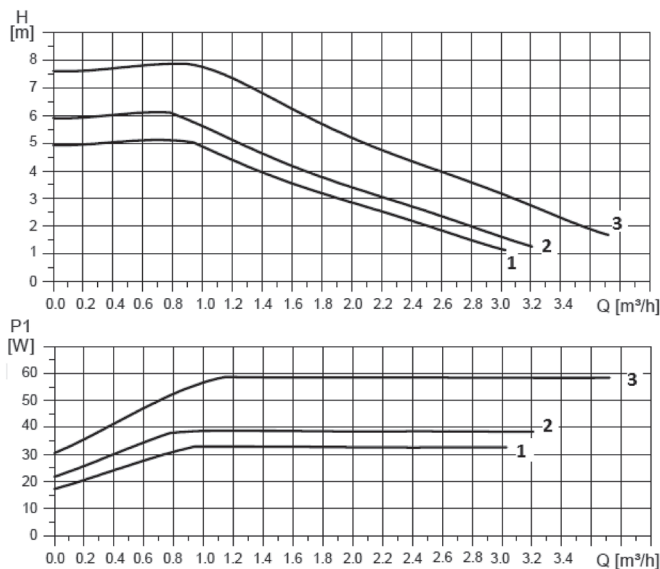

Curve	Max. H (upper graph)	Max. P ₁ (lower graph)
1	5 m	33 W
2	6 m	39 W
3	7.5 m	60 W

DATA SHEET

CSE2 MIX F G75 1F Pump Station

Pump Electrical Wiring

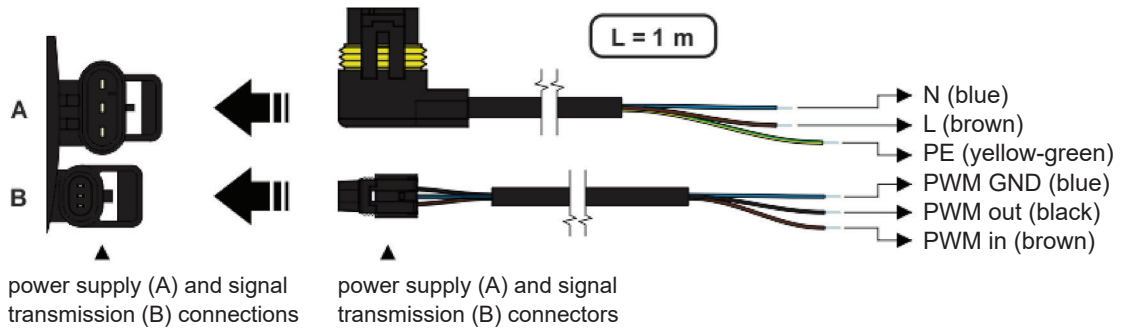

Pump Station Pressure Drop

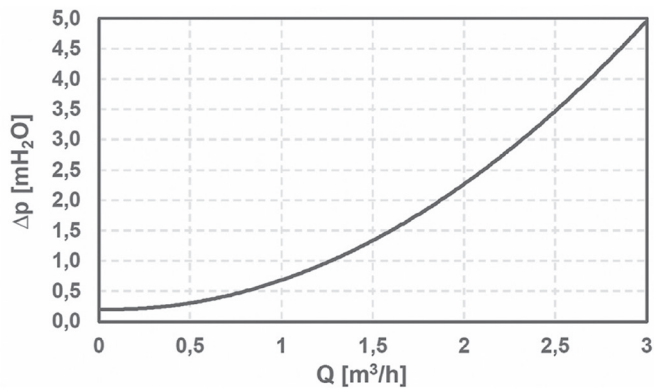

Actuator electrical wiring

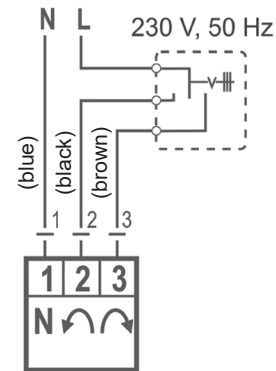

Example of possible connection

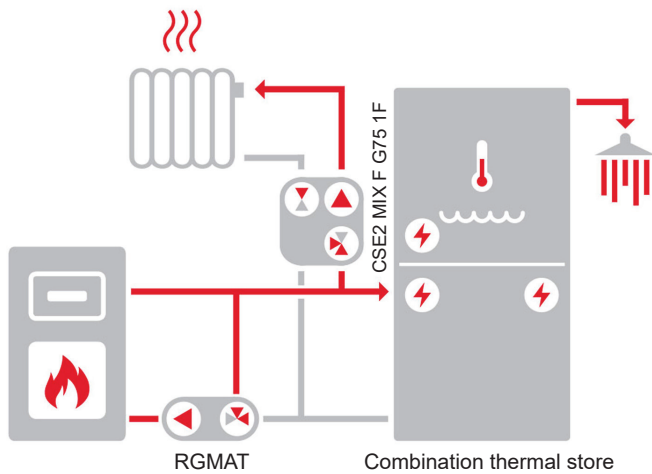

The diagram shows a typical connection of a solid fuel boiler (with the recommended RGMAT pump station – not included in supply), combination thermal store and heating circuit.