

DATA SHEET

Safety Kit for Hot Water Storage Tanks up to 200 liters, G 3/4" F/M



Main Features

Description	<p>The safety kit is used to protect the hot water storage tank from exceeding the maximum working pressure, to check the function of the check valve and to drain the hot water storage tank. The kit contains all components for pressure protection of the HW storage tank:</p> <ul style="list-style-type: none"> ● safety valve ● check valve ● checking valve to verify the function of the check valve ● drain valve ● pressure gauge ● cold water shut-off valve to the hot water storage tank <p>The safety valve protects the hot water storage tank from exceeding the maximum working pressure. The check valve prevents water from flowing back into the water supply line. The ball valve allows to check the function of the check valve or to close the water supply and subsequently drain the tank through the drain valve. The safety kit allows to connect an expansion vessel – the G 3/4" M inlet for the expansion vessel connection is located opposite the pressure gauge inlet and is fitted with a blind cap from the factory.</p>
Installation	<p>The safety kit installs on the cold water supply pipe upstream of the hot water storage tank; if necessary, the pressure gauge can be connected to the opposite inlet and a mirror variant of the kit made; no shut-off valve, non-return valve or filter may be installed between the HW storage tank and the safety kit; it is necessary to ensure free drainage of liquid from the safety and drain valves.</p>
Working fluid	drinking water
Max. working temperature	80 °C
Connections	G 3/4" F x G 3/4" M

Kit Codes

Code	Safety valve opening pressure	Safety valve thread	Safety valve seat cross section	Discharge coefficient	Kit total weight	HW Storage Tank Max. Output*	HW Storage Tank Max. Volume*
17387	6 bar	G 1/2" F-M	132,73 mm ²	0,3	870 g	75 kW	200 l
18272	7 bar						
18288	8 bar						
18274	10 bar						

* Following the EN 1488 standard

DATA SHEET

Safety Kit for Hot Water Storage Tanks up to 200 liters, G 3/4" F/M

Materials

Safety kit and ball valve housing	brass CW617N
Check valve housing and cone	POM Hostaform
Check valve spring	AISI 302
Gasket	EPDM

Connection Diagram

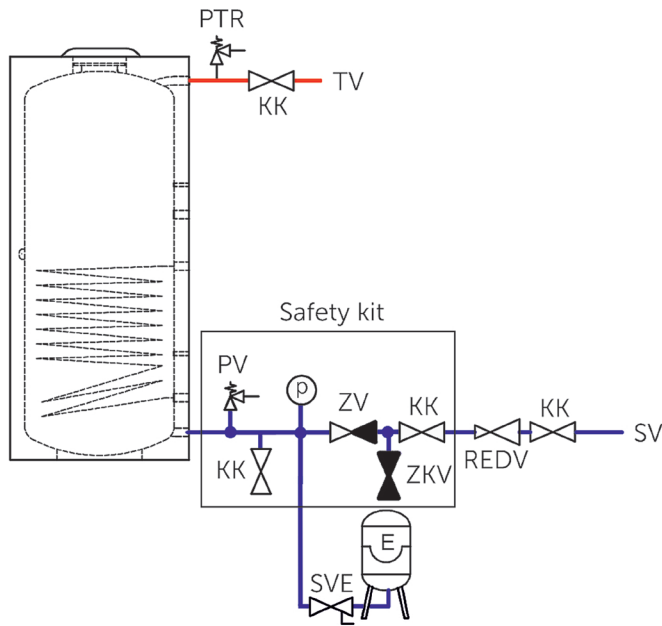

LEGEND

- PTR - safety temperature-pressure relief valve
- KK - ball valve
- PV - safety valve
- ZV - check valve
- ZKV - checking valve
- SVE - expansion vessel service valve
- REDV - pressure reducing valve
- TV - domestic hot water
- SV - cold water

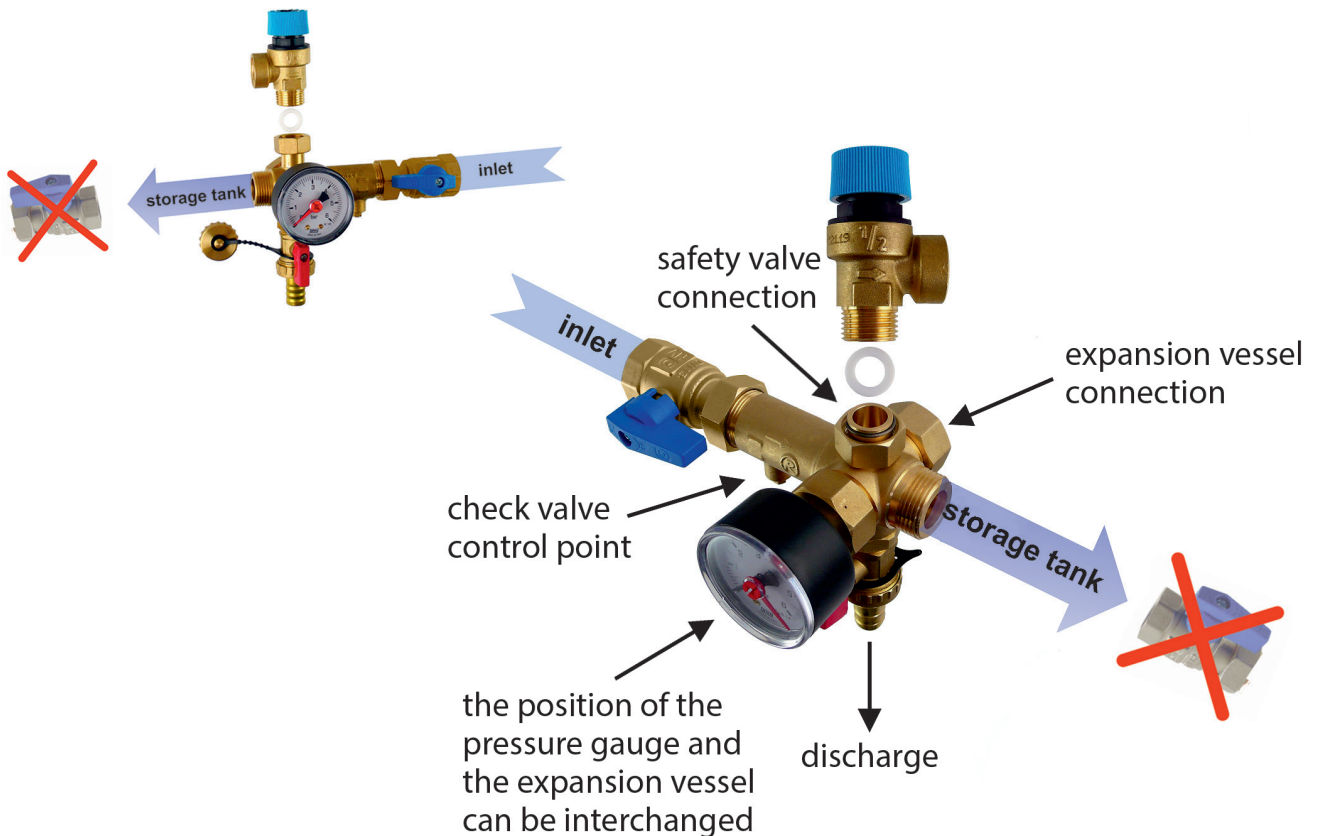

DATA SHEET

Safety Kit for Hot Water Storage Tanks up to 200 liters, G 3/4" F/M

Dimensions of the assembled kit

